

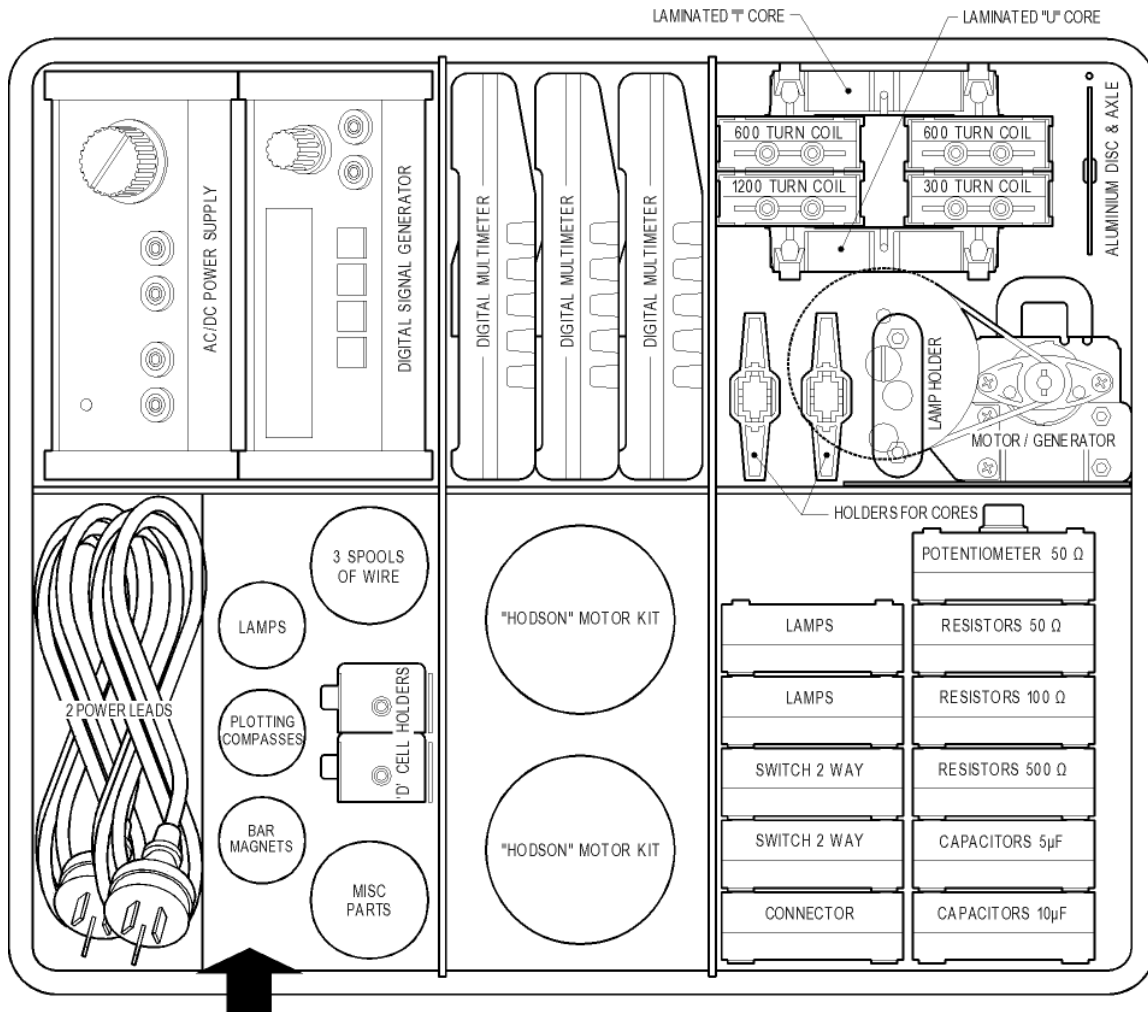



ELECTRICITY KIT - Experiments for AC & Motors

Cat: EM1763-020 KIT LAYOUT



SET OF 12 CONNECTING LEADS IN ZIP BAG
PACK ON TOP OF POWER LEADS



**SCIENCE
&
EDUCATION**

ISO 9001

INDUSTRIAL EQUIPMENT & CONTROL P/L
MELBOURNE AUSTRALIA

3 SPOOLS VIAL CONTAINS:

- 1 ROLL BARE COPPER 0.2mm DIA.
- 1 ROLL RESISTANCE (CONSTANTAN) WIRE 0.2mm DIA.
- 1 ROLL FUSE WIRE 1A, 0.05mm DIA.
- 4 WIRES FOR METER μ F
- 2 PAPER CLIPS

MISC PARTS VIAL CONTAINS:

- 4 ALLIGATOR CLIPS TO FIT TO BANANA PLUGS
- 4 ALLIGATOR CLIPS WITH BANANA PLUGS
- 1 PAIR, ELECTRODE PLATES, ZINC & COPPER
- 1 PAIR, CONDUCTIVITY PLATES, S/STEEL
- 1 RING FOR THOMSON'S EXPERIMENT
- 1 COMPASS FOR CHECKING N/S POLES

PART 2

**Experiment list: for D.C.****Experiment list for A.C. & Motors**

1	Turn lamp on and off	41	AC current in capacitors. Reactance.
2	Select between 2 lamps	42	AC current in inductors. Reactance, Impedance
3	Operate a lamp from 2 switches	43	Magnetising fields, theory & concepts
4	Voltage measurement, 1x cell	44	Field around a straight conductor
5	Voltage measurement, 2x cells in series	45	Field around a single coil
6	Voltage measurement, 2x cells in parallel	46	Field in a solenoid
7	Current measurement using ammeter.	47	Theory of induction. Moving coil, stationary field
8	Conductors and non-conductors	48	Stationary coil, moving field.
9	Can liquids carry current ?	49	Use a coil to provide the field
10	Smaller currents through liquids	50	Using AC instead of DC
11	Ohm's Law, using wires (part 1)	51	Transformers & coils
12	Ohm's Law, using wires (part 2)	52	Coil direction. Clockwise & Anticlockwise
13	Ohm's Law, using wires (part 3)	53	Choosing meters for measurement
14	Ohm's Law, using wires (part 4)	54	Why do transformers use AC ?
15	Ohm's Law, using wires (part 5)	55	Laminated iron cores
16	Using Ohm's law. Resistors in series	56	Magnetising current
17	Is a lamp a resistor ?	57	Useful eddy currents
18	Connecting 2 lamps in series. Short	58	The transformer
19	Connecting 2 resistors in series	59	Leakage in iron cores
20	Voltage divider using resistors	60	Measure DC magnetising current
21	Connecting 2 lamps in parallel	61	Measure AC magnetising current
22	Connecting 2 resistors in parallel	62	Connect coils in different ways. Buck and Boost
23	Connecting resistors in series/parallel	63	Thompson's ring experiment
24	Internal resistance of a cell	64	Measure DC resistance of a Resistor
25	Why use 2 cells in parallel ?	65	Measure the DC Resistance of an Inductor
26	Making a Voltage Divider using wire	66	Measure AC resistance using AC volts & amps
27	Using a potentiometer (voltage divider)	67	Measure the Impedance of an Inductor
28	Making a Rheostat from a potentiometer	68	Measure the Reactance of an Inductor
29	Creating heat energy from electricity	69	Measure the Inductance of an Inductor
30	Creating light energy from electricity	70	Measure the Impedance of a Capacitor
31	Making a fuse	71	Measure the Reactance of a Capacitor
32	Power in an electrical circuit	72	Measure the Capacitance of a Capacitor
33	Making a heater for water	73	Capacitors in series and parallel
34	Work performed by an electric current	74	Resonance: Inductor and Capacitor in series
35	Voltage created by chemistry	75	Resonance: Inductor and Capacitor in parallel
36	Capacitors charge and voltage	76	Power Factor
37	Charge one capacitor from another	77	DC Generators, permanent magnet, adj.field.
38		78	AC Generators, permanent magnet, adj.field.
39		79	DC Motors, shunt, series.
40		80	AC Motors, series, synchronous.

A.C. EXPERIMENTS: Look at the Glossary to learn the meaning of “AC”.

41) AC current through capacitors: Capacitive Reactance:

Equipment required:

- 1x Power Supply, 2-12V.AC/DC
- 1x switch, single pole, 2 way
- 1x capacitor, 10uF
- 2x capacitors, 5uF
- 1x multimeter or voltmeter 0-20V.AC.
- 1x multimeter or ammeter 0-100mA.AC.
- 6x cables with banana plugs

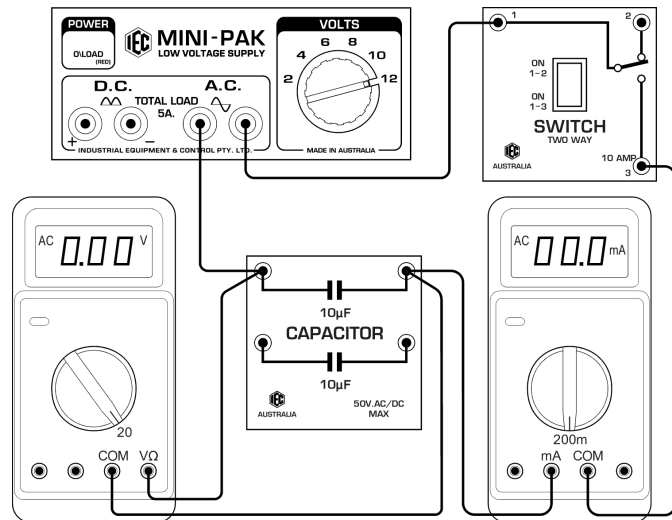
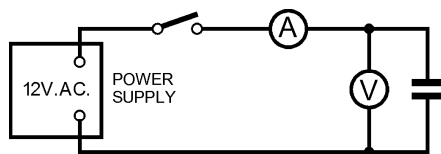

Connect a switch, 10uF capacitor and 200mA ammeter in series across a power supply set to 12V.AC. Connect a 20V.AC. voltmeter across the capacitor.

The resistance in ohms of a resistor controls the current flowing through it. A capacitor or inductor (to be studied later) has a similar “resistance” but it occurs only when AC power is used and it is called “Reactance”. Read about Reactance in the Glossary.

Close the switch and note the AC current flowing through the capacitor and the AC voltage across the capacitor.

Change the capacitor to a 5uF capacitor and again note the voltage and the AC current flowing.

What do you notice when the capacitance is halved from 10uF to 5uF ?

Use a cable to connect the two 5uF capacitors in series to make a 2.5uF capacitor. Now use these in the circuit and again note the AC current flowing.

What do you notice when the capacitance is 2.5uF ?

Now connect all 3 capacitors in parallel to make 5uF + 5uF + 10uF = 20uF total.

What do you notice when the capacitance is 20uF ?

The Reactance of the capacitor is AC Volts / AC Amps (similar to a resistor). Take your readings and calculate the reactance in ohms.

EXAMPLE: say 12V.AC. applied and 37mA (0.037A) in capacitor = $12 / 0.037 = 324$ ohms.

To calculate reactance when the capacitance is known, the formula is: $R_c = 1 / (2\pi fC)$

R_c is Capacitive Reactance, $\pi = 3.142$, f is frequency (50Hz), C is capacitance in **Farads**.

For a 10uF capacitor at 50Hz, reactance is: $1 / (2 \times 50 \times \pi \times 10 \times 10^{-6}) = 322$ ohms

For a 5uF capacitor, reactance is 644 ohms. So we see large capacitors have lower reactance.

NOTE: The above calculations are for pure capacitance. In practice, there is always some combination of capacitance and resistance (wires etc.) so some resistance should be added to the Reactance calculation to give total “Impedance” in ohms.

Read the Glossary about “Impedance”.

42) AC current through inductors: Inductive Reactance:

Equipment required:

- 1x Power Supply, 2-12V.AC/DC
- 1x switch, single pole, 2 way
- 1x 'U' and 'I' core
- 1x 300 turn coil
- 1x 600 turn coil
- 1x multimeter or voltmeter 0-20V.AC.
- 1x multimeter or ammeter 0-500mA. AC
- 6x cables with banana plugs

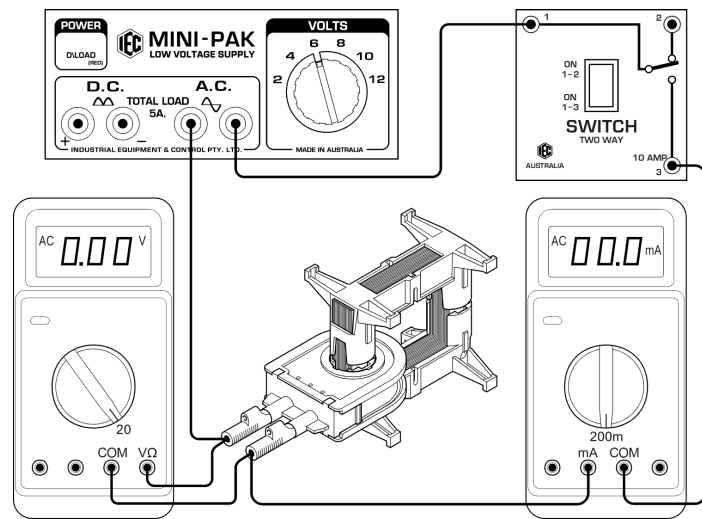
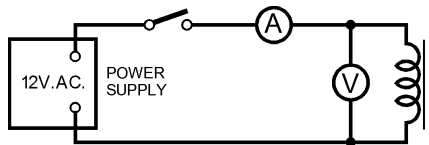

Connect a switch, a 300 turn coil mounted on the closed iron core and ammeter in series across a power supply set to 6V.AC. Connect a 20V.AC. voltmeter across the coil.

The resistance in ohms of a resistor controls the current flowing through it. An Inductor or Capacitor has a similar "resistance" but it occurs only when AC power is used and it is called "Reactance". Read about 'Reactance' and 'Inductor' and 'Choke' in the Glossary.

Close the switch and note the AC current flowing through the inductor (or choke) and the AC voltage across the inductor.

Change the inductor to the 600 turn coil and again note the AC current flowing.

What do you notice when the coil turns are doubled from 300 to 600 turns ?

Place both coils on the iron core (one above the other) and use a cable to connect the two coils in series to make a 900 turn coil. Connect the **Finish** of one coil to the **Start** of the next. Now use this in the circuit and again note the AC current flowing.

What do you notice when the coil has 900 turns ?

The Reactance of the inductor is AC volts / AC amps (similar to a resistor). Take your readings and calculate the reactance in ohms.

EXAMPLE: say 6V.AC. applied and 0.1A in the coil = $6/0.1 = 60$ ohms.

To calculate reactance when the inductance is known, the formula is: $R_i = 2\pi fL$

R_i is Inductive Reactance, $\pi = 3.142$, f is frequency (50Hz), L is inductance in **Henry**.

If Reactance of a coil is 60 ohms at 50Hz, inductance = $60 / (2 \times 50 \times \pi) = 0.191$ Henry (191mH)

If the reactance was double, all the other factors would remain the same except for the inductance which would also double in size. So we have learned that large inductors have large reactance.

In the case of capacitors, it is the opposite because large capacitance has a low reactance.

NOTE: The above calculations are for pure inductors. In practice, there is always some combination of inductance and capacitance and resistance (wires etc.) so the resistance and (in some cases) the capacitive reactance must be added to the calculation to give total "Impedance" in ohms.

Read the Glossary about "Impedance".

43) MAGNETIC FIELDS & INDUCTION:

A FEW BASIC CONCEPTS FOR TEACHERS AND STUDENTS:

Conventions:

- 1) By convention, a magnetic field is normally depicted flowing from a North pole to a South pole.
- 2) By theory, electrons (negatively charged) flow from a more negative potential to a more positive potential whereas conventional current flows from positive potential to negative. In this booklet, we deal only with conventional current flow.

An interesting diversion regarding conventions: The tip of a magnetic compass that points north is the north pole of the needle. To confirm this, hold a bar magnet by cotton at its mid point so it can swing freely. The end marked 'north' points to the north magnetic pole of the earth. Of course, the direction to which the north end of a magnet is attracted must really be a South Pole. So, we must assume that the naming of the North and South poles of the earth is simply another "convention".

Current flow: When considering the current flow in a conductor where the conductor itself is generating the EMF, the polarity of the current flow appears to be reversed to the polarity of the current flow in the external circuit. For example, if current flows from Positive to Negative in a battery external circuit to say a lamp, it must be flowing from negative to positive INSIDE the battery.

Left Hand Rule (for motors), Right hand Rule (for generators): The left hand rule is a quick way to determine the direction of movement in a wire when the direction of the magnetic field and the direction of the current flow is known, as in the case of a motor. The Right Hand Rule using the same markings for the fingers, is used to find the direction of the current flow when the motion and the magnetic field directions are known, as in the case of a generator. Try it and see.

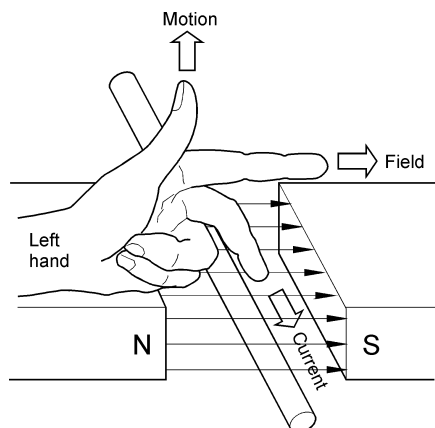

LEFT HAND MOTOR RULE
CURRENT & FIELD KNOWN, FIND MOTION

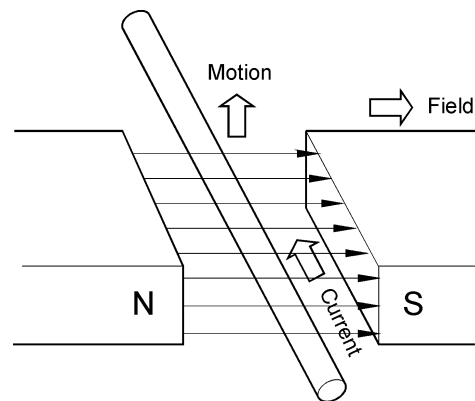

RIGHT HAND GENERATOR RULE
MOTION & FIELD KNOWN, FIND CURRENT

Right Fingers rule (for magnets): The Right Fingers Rule is useful to determine which end of an iron circuit becomes North Pole when the direction of the current in the coil is known. This is useful for magnets and transformers.

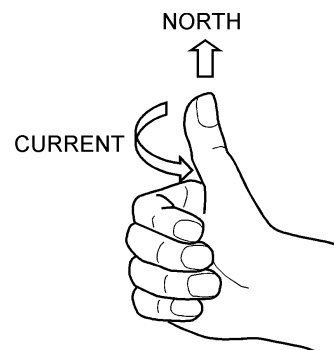
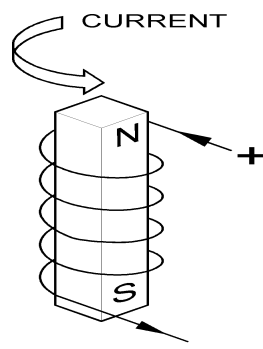

DEMONSTRATORS TO SHOW HOW MAGNETIC FIELD FORM AROUND WIRES:

The kit has a set of 3x demonstrators and these can be used on an overhead projector. Some designs use one single turn of thick wire to form the coils. At small currents of 5A, they work well with sensitive 'plotting compasses' but a very large current is required through one single turn to create a field strong enough to move iron filings. To overcome this problem, our units have 10 turns of wire so the field is strong enough to move iron filings, but the field shape is the same as one single turn.

Connect a coil unit to the power supply set to 2V.DC. **DO NOT EXCEED 2V.DC. OR THE COIL WILL OVERHEAT AND THE UNIT WILL BE DAMAGED.**

44) MAGNETIC FIELD AROUND A STRAIGHT WIRE: use rectangular coil unit.

Direction of the current: Looking at the rectangular coil with the RED socket at the left side and connected to the +ve socket on the power supply, the current flow is anticlockwise around the coil.

Place several 'plotting compasses' on the flat surface around **ONE OF THE LEGS** of the coil to see the shape and direction of the magnetic field formed by a straight wire.

OR..... Sprinkle a small quantity of iron filings on the flat surface close to the leg and tap the surface with your fingernail to slightly shake the iron filings. See the lines of magnetic field form on the surface.

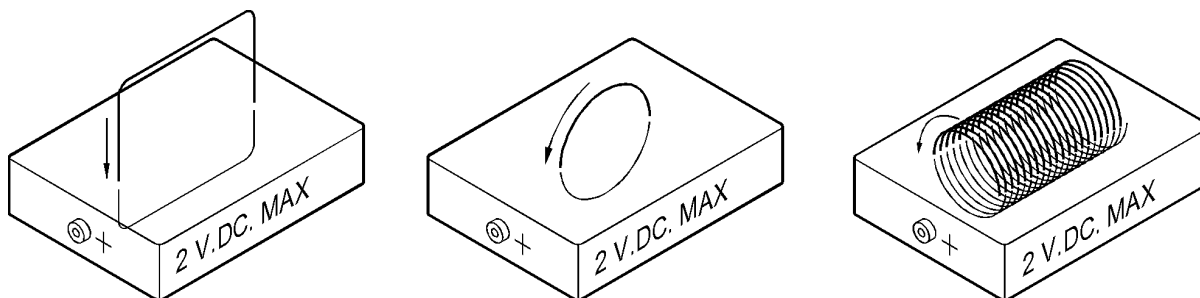
**45) MAGNETIC FIELD FROM A SIMPLE COIL: use the small round coil unit.**

Direction of the current: Looking at the round coil with the RED socket at the left side and connected to the +ve socket on the power supply, the current flow is anticlockwise around the coil.

Place several 'plotting compasses' on the flat surface around the coil to see the shape and direction of the magnetic field formed.

OR..... Sprinkle a small quantity of iron filings on the flat surface and tap the surface with your fingernail to slightly shake the iron filings. See the lines of magnetic field form on the surface.

46) MAGNETIC FIELD IN A SOLENOID: use the brass spiral coil solenoid unit.

Direction of the current: Looking at the coil with the RED socket facing towards you and connected to +ve socket on the power supply, the current flow is anticlockwise around the coil.

Place several 'plotting compasses' on the flat surface around the solenoid to see the shape and direction of the magnetic field formed by a solenoid.

OR..... Sprinkle a small quantity of iron filings on the flat surface and tap the surface with your fingernail to slightly shake the iron filings. See the lines of magnetic field form on the surface.

47) THEORY OF INDUCTION:

If a conductor is moved in a magnetic field so that the conductor cuts the lines of magnetism, a small EMF (Electro Motive Force or Voltage) is induced in the conductor whilst it is moving. The voltage reverses if the direction of motion reverses. If motion stops, the EMF is zero.

If the conductor is moved so that the conductor moves **parallel to** but **does not cut** through the lines of magnetic force, the EMF produced is zero.

The size of the EMF increases if the magnetic field is stronger, if the motion is faster or if many turns are used (see drawing below).

NOTE TO TEACHERS: To measure the current in the circuits below, a very sensitive galvanometer is required. The EMF generated in the wire is very small, so it is very important that the **impedance** of the galvanometer is very low (this is often difficult to arrange). It is possible that a coil of 20 turns or more will be required to generate a high enough voltage to drive a school meter.

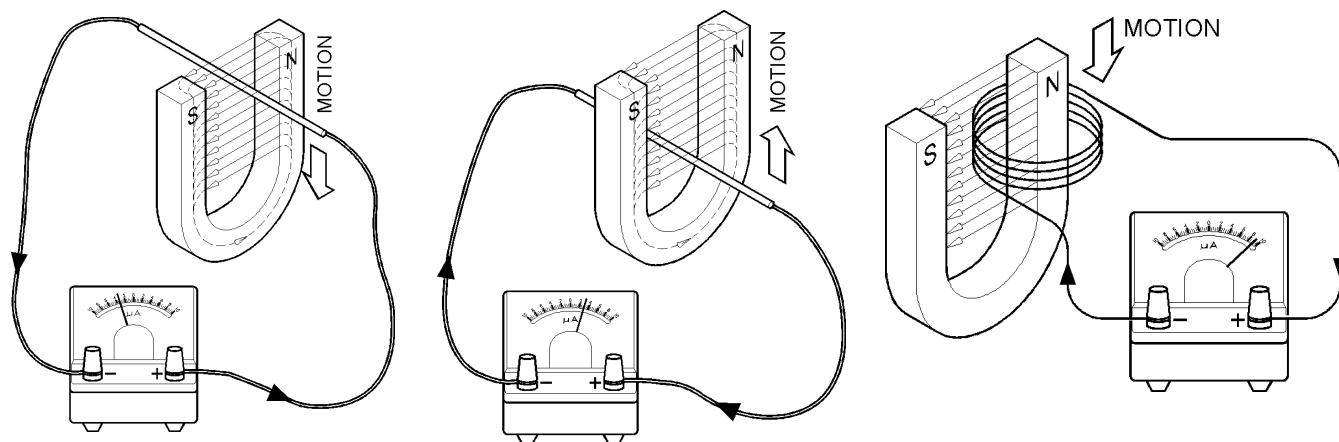

48) LEAVE THE COIL ALONE AND MOVE THE MAGNETIC FIELD:

Connect a coil as shown and move a bar magnet as shown. Notice the voltage is generated in the coil only while the magnet is moving. If the magnet could be made to go back and forth continuously, there would be a 'back and forth' voltage generated continuously. Try it and see.

The direction that the galvanometer deflects depends on the direction of the winding of the coil (clockwise or anti-clockwise), the end of the magnet (north or south) and the direction of movement (up or down). Reverse the various things and try it. Remember that if a coil is simply turned over, the direction of the coil (clockwise or anti-clockwise) reverses.

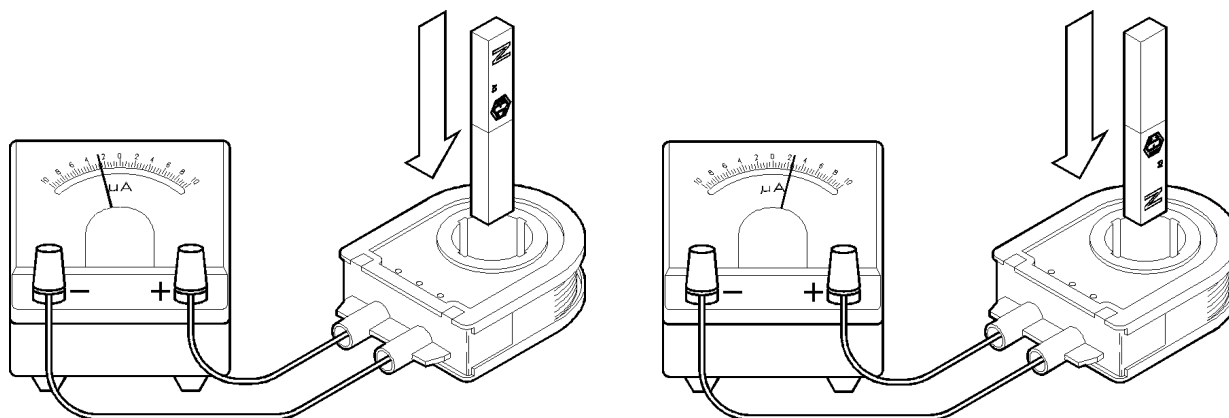

49) USE ANOTHER COIL TO PROVIDE THE MAGNETIC FIELD:

The magnetic field does not need to be provided by a permanent magnet. Another coil can be used to create a magnetic field. Prove this by placing the long iron bar inside the 200 turn primary coil and apply say 2 or 4 volts DC from a battery to the coil terminals. Notice that the iron bar becomes magnetised. Use the magnetic compass to prove the bar is magnetised north at one end and south at the other end. If you know the direction of the winding, use the 'Fingers Rule' to check the north and south ends of the iron bar.

Place two coils side by side and connect as shown below. One can be the 200 turn primary coil and the other can be one that you wound yourself with say 100 turns. Apply DC voltage from a battery to the coil that is not connected to the galvanometer. Notice that when the coil is first connected and the magnetic field is first created, the other coil causes the galvanometer to deflect momentarily. Notice that when the battery is disconnected and the field collapses, the galvanometer deflects momentarily in the opposite direction.

Reverse the polarity of the connection and see the galvanometer deflect the opposite direction during connection and disconnection.

When the magnetic field is established and no longer forming or collapsing (not varying) the galvanometer shows zero current.

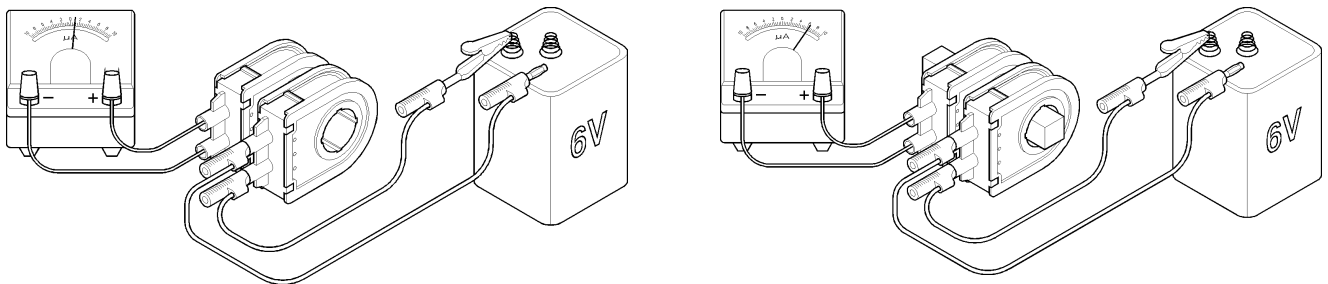

In the left side arrangement, the two coils are coupled only by air. If an iron bar is placed inside the coils, the coupling is greatly improved and the galvanometer deflection is increased. It is proven that an 'Iron Circuit' inside the coils greatly improves the magnetic coupling between them.

NOTE: Use a large battery for smooth DC current to be applied to the coil to form the magnetic field. If the DC voltage is only half or full wave rectified, the DC voltage will be rising and falling 100 times per second and the galvanometer needle will be vibrating and will be much less sensitive.

50) USING AC INSTEAD OF DC:

Using the same arrangement of two coils and the iron bar as shown in the right side illustration above, take a power pack and apply 6 volts AC to the coil from a power supply instead of DC. AC reverses its direction 100 times per second. This means that the induced EMF in the other coil will reverse 100 times per second. This is so fast that the galvanometer cannot follow the changes and the galvanometer needle just vibrates slightly and appears to read zero. Replace the Galvanometer (a DC instrument) with an AC voltmeter which is designed to read AC voltages.

If an oscilloscope is used instead, the AC waveform (a sine wave) can easily be seen.

The presence of a proper closed iron circuit between the coils greatly improves the efficiency of the system, **but we now have a simple device that is fed with an AC current and continually generates an AC voltage in another coil. This device is called a Transformer.**

**51) TRANSFORMERS and COILS:**

Examine the 'U' core and the 'I' core provided. The kit has 2x 300T coils and 1x 600T coil.

One of the 300 turn coils should be used as the Primary coil. This is the correct number of turns for the primary coil and will fully magnetise the iron core when connected to 12 volts AC. If connected to 12 volts DC, the current will be too high and the coil will get hot. If DC operation is desired, use a lower voltage of say 2 to 6 volts DC.

The coils provided have their wire terminated to 4mm sockets so that banana plugs can be used for connection. The label on each coil shows the number of turns, the Start and Finish (S & F) of the winding and the direction of current flow around the coil from Start to Finish.

The kit has another 300 turn coil and a 600 turn coil. These can be used as secondary coils or as additions to the primary coil. If the 600 turn coil is used as a primary coil at 12V.AC., the iron will be only partly saturated with magnetic field. The transformer will be run but at low efficiency.

52) COIL DIRECTION: CLOCKWISE or ANTI-CLOCKWISE:

The direction of the winding is important to predict the polarity of the induced EMF. Notice that if the coil is turned upside down, the direction of the winding is reversed and clockwise (same direction as clock hands move on a clock's face) becomes anti-clockwise when looking from above the coil.

When using DC, the magnetic field produced by the coil will be reversed if the coil winding direction is reversed or if the coil is turned over.

When using AC, if the coil is turned over, the 'phase' of the voltage produced in the coil will be reversed (see 'Phase' in the glossary). If one secondary coil is reversed to another secondary coil, their phases will be reversed. This means that while the voltage is rising during 100th of a second in one coil, the voltage in the other coil will be falling during that short time. If they were joined in series, one coil voltage would subtract from the other coil voltage (see 'buck' in the glossary). If both coils had equal turns, the resultant voltage would be zero. If both coils were the same direction, the resultant voltage would be double (see 'boost' in the glossary).

53) CHOOSING METERS FOR MEASUREMENT:

For basic induction work, sensitive DC meters or sensitive Galvanometers are best. Galvanometers measure very small currents of around 20 to 50 microamps. This is required to see currents flowing as single conductors are moved in a magnetic field.

Student analogue bench meters of 0-1mA or 0-10mA DC are required for monitoring currents if coils with many turns are creating current with bar magnets and so on.

For transformer work, AC meters are always required. 0-20V.AC analogue or digital student bench meter or multimeter is probably best for primary coil volts. Another one or two 0-20V.AC or 0-10V.AC meters would be required for monitoring secondary coils for experiments.

Two digital or analogue student bench AC ammeters around 0-1A / 0-10A.AC. either single or dual range will be needed for primary currents. An additional 0-10A.AC analogue meter would be useful for showing short circuit currents and similar in secondary coils.

Analogue multi-meters can be used but many do not have AC ranges of current that suit the experiments. Also there is a risk of selecting the wrong voltages or currents.

DIGITAL METERS:

Digital multimeters are supplied in the kit and are more accurate than analogue meters. These can be used for AC or DC measurements but the changes in voltage will not easily be seen as the numbers jump. But for general measurement of steady voltages and currents they are satisfactory.

54) WHY DO TRANSFORMERS USE 'AC' INSTEAD OF 'DC' ?

We have seen that the EMF is created in the second coil only when the DC magnetic field changes. There is no EMF when the magnetic field from the first (the primary) coil is steady. Therefore, if AC is used and the field is continually rising falling and reversing 100 times per second, a continuous AC EMF is generated in the second coil. This means that a useful amount of energy is continuously being transferred from one coil to the other.

This Induction Kit is to learn about transformers which are devices that run on AC only. AC is applied to one coil and an iron circuit couples the energy from this coil to another coil. If the number of turns in each coil is the same, the voltage applied to the primary coil will induce the same voltage in the secondary coil because the same magnetic field is coupled by the iron core through both coils.

If the secondary coil has say half the number of turns of the primary coil, the voltage from the secondary coil will be half the voltage applied to the primary. If the secondary coil has 10 times the number of turns of the primary coil, the voltage on the secondary will be 10 times the primary voltage. This is the main function of a transformer – to TRANSFORM one voltage to another voltage. This is how the dangerous 240V.AC. from the power point can make say a safe 6 volts to charge a mobile phone. The little black box that is used contains a Transformer.

Another function of a Transformer is to provide a voltage that is not electrically connected to the original power source (called an Isolating Transformer). This results because the two coils are not electrically connected to one another and the energy is passed from one coil to the other by the magnetic field in the iron circuit that couples them.

Transformers can be depicted in several ways, but a common method is shown below. The first transformer shows a primary coil and a single secondary coil and the second transformer shows a primary coil with two secondary coils. The parallel bars represent the iron core that links the primary and secondary coils together.

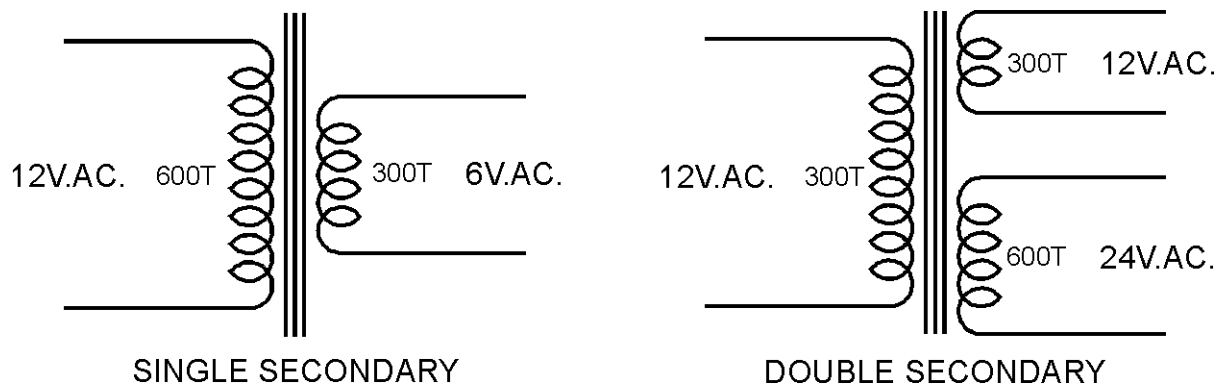

In some cases, if a very high voltage is required, a secondary winding might have many thousands of turns and in other cases, for very low voltages, the secondary might have only one single turn. Usually, if the secondary turns are many, the current available from the secondary is small and, conversely, if the secondary turns are small, the current can be thousands of amps for welding or electro-plating or similar purposes.

Multiple secondary coils can be connected in different ways to provide different voltages from the transformer. In the right hand example, if the two secondary coils were connected in series, it is equivalent to a coil of 150 turns. Examples will be seen later in this booklet.

55) LAMINATIONS AND IRON CORES:

Why is the iron core 'laminated' instead of using a solid iron core ?

We know that when the AC magnetic field is created, the lines of magnetic force (called Flux) cut the turns in the secondary coil and produce a voltage. Current can flow from the secondary coil only if an external circuit is connected to the secondary coil.

But the same flux cuts the iron too and the iron material is also a conductor of electricity. A small voltage is induced across the thickness of the iron core and because of this small voltage across the iron core, a strong current can flow inside the iron core as if it were a secondary coil with a short circuit connected. This current robs energy from the primary coil and also makes the iron heat up.

To prove this important point, proceed as follows: Lift the 'I' core and remove the secondary coil. Re-fit the 'I' core and connect an AC ammeter in series with the primary coil and connect to 12V.AC. Make note of the amps flowing into the primary.

Then remove the laminated 'I' core and replace it with the solid bar of iron. See below.

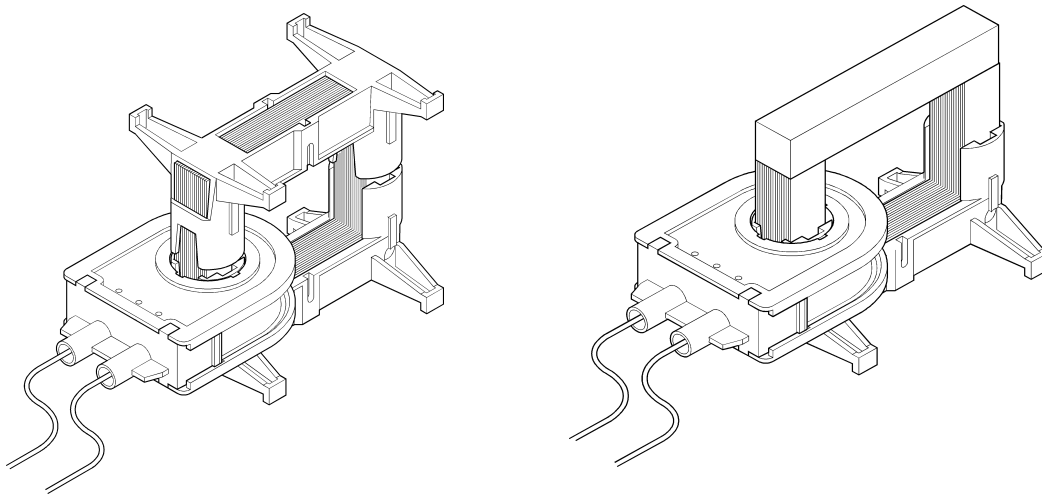
**56) MAGNETISING CURRENT:**

Magnetising current is the current flowing in the primary coil only to create the magnetic field in the iron circuit. Measure the primary current again. For an efficient transformer this wasteful and useless energy loss is avoided and reduced to a minimum by good transformer design. Having a laminated core keeps circulating currents inside the iron to a minimum and keeps the magnetising current low.

With the solid bar in place, notice the big rise in magnetising current because of the unwanted currents flowing in the iron bar. Leave the system for say 5 or 10 minutes. Notice the rise in temperature of the iron bar as the energy of the circulating currents heats up the iron.

If a laminated iron core is used, the separate laminations stop most of the circulating current in the iron and the serious loss of energy stops. You will notice that all AC devices, transformers, magnets or motors etc. always use laminated cores.

If the motor or magnet device is a DC device, lamination of the iron core is not necessary because the magnetic flux is steady and not constantly cutting the iron 100 times per second. Therefore there are no circulating currents induced in the iron.

Circulating currents in solid materials are sometimes called 'Eddy Currents'.

57) USEFUL EDDY CURRENTS:

When moving magnetic fields cuts through solid metal materials, circulating currents, or 'Eddy Currents' flow inside the solid materials. These currents create a magnetic field of their own and these magnetic fields oppose the magnetic fields that created them.

Place the 300 turn primary coil on one leg of the 'U' core and position 2 short iron cores as shown in the illustration below. Clamp them down to the tips of the 'U' core using the small plastic frames and rubber bands.

Make the air gap between the poles about 4 or 5mm.

Take the metal disc with the rubber centre and press the metal axle through the rubber so the disc is about the mid point of the axle. Be sure the disc is straight and does not wobble sideways.

Rest the axle in the small 'Vee' slots in the tops of the plastic frames so that the disc hangs between the poles in the air gap. Spin the axle with the fingers so that the disc spins fast. If it just touches the poles momentarily it does not matter, but it is better if it does not touch as it spins. Practice spinning it a few times with the finger tips of one hand.

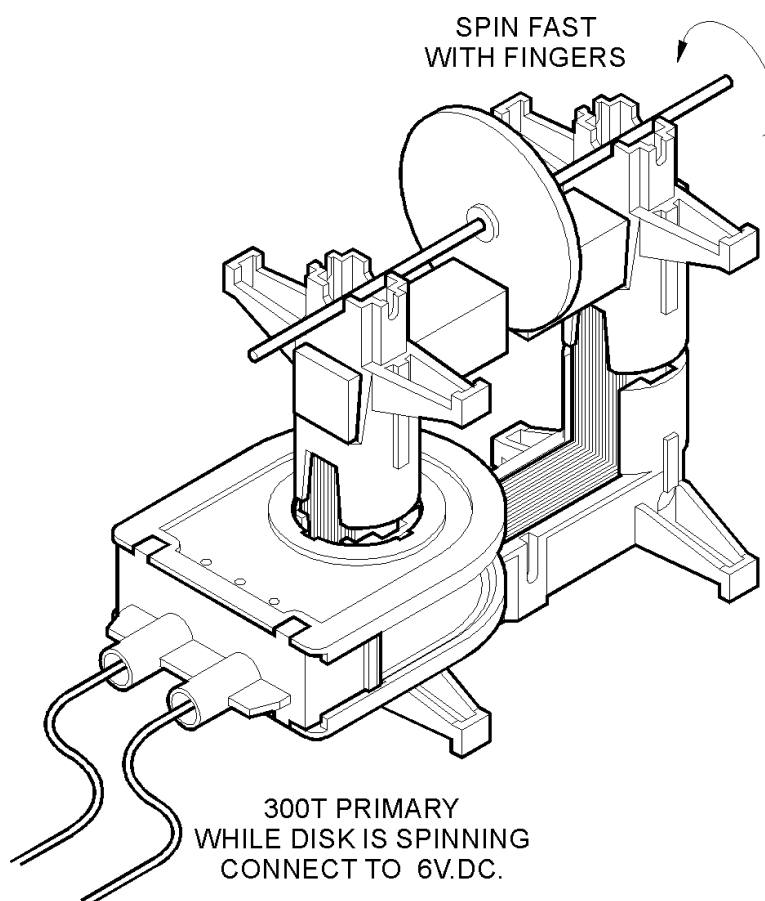

While the disc is spinning fast, connect the coil momentarily to a DC power source (battery or DC power supply at about 6 volts DC). **Notice what happens to the spinning disc.**

The reason the disc stops spinning quickly is that when the DC field is applied to the air gap, 'Eddy Currents' flow in the disc as it spins through the magnetic field. The resulting magnetic field around the disc caused by the eddy currents flowing in the disc metal opposes the field in the poles. This opposition of the two fields slows the disc rapidly.

This principle is used in industry as a type of braking system for spinning devices such as disc drives in computers and so on.

58) THE TRANSFORMER:

Take the 'U' core in the plastic holder and 'I' core in the plastic holder. Place the 300 turn primary coil over one leg of the 'U' core and place a secondary coil of either 300 or 600 turns over the other leg of the 'U' core.

Invert the 'I' core and carefully place it over the 'U' core as shown below.

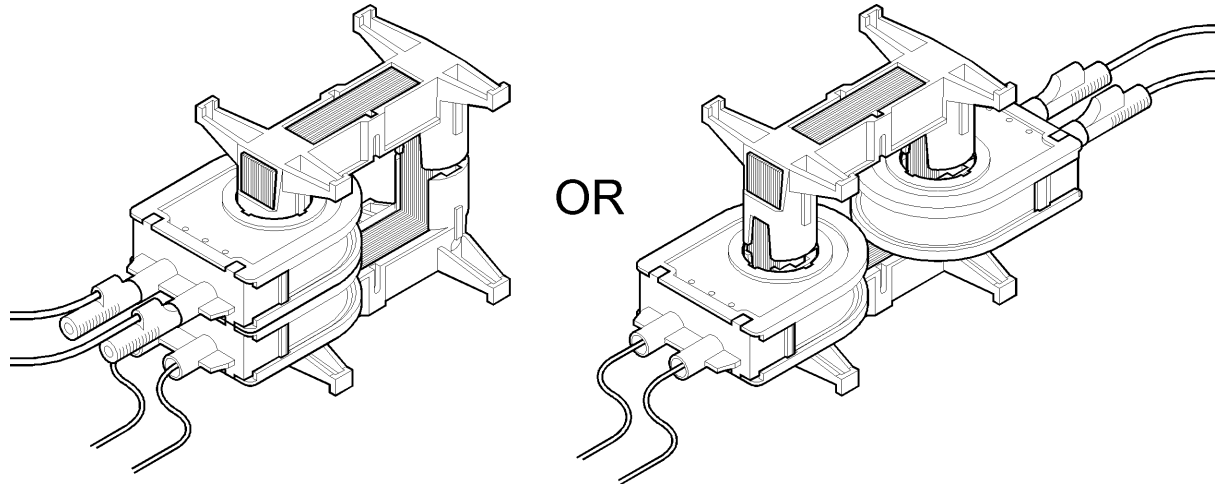

The 4x rubber bands can be stretched between the legs, top to bottom, to hold the two halves of the transformer firmly together.

Apply say 12 volts AC to the 300 turn primary coil and, using an AC voltmeter, measure the output voltage from the 300 turn secondary coil. It should be close to 12V.AC.

Two coils can be fitted to either side of the transformer core and they can face from the ends of the iron core or across the iron core. It does not matter which are the primary and which are the secondary coils because the iron circuit passes through them on either side of the transformer, but one of the 300 turn coils supplied is normally used as the primary coil and is connected to 12 Volt AC power source with the cables supplied with the banana plugs fitted.

For transformer study, normally the iron core is fitted and the iron is closed tightly so there is no air space between the iron laminations and therefore minimum magnetic leakage. The rubber bands supplied pull the iron tightly together. If the iron core is not fully closed tightly, the voltages measured on the secondary coils will not accurately follow transformer theory.

59) LEAKAGE IN IRON CORES:

To test for magnetic leakage, take the small steel axle used for the Eddy Current disc and hold it close to the corners of the transformer core. If leakage is present, a vibrating magnetic field will be felt in the axle. Place small pieces of paper between the tips of the 'U' core and the 'I' core to create small 'Air Gaps' between the cores. Check for leakage again. Check again at different primary voltages. At 12V.AC, check the difference in coil magnetising current with and without the paper present.

60) MEASURE DC MAGNETISING CURRENT:

DC would be used only if electro-magnets are to be made. If a coil is fed with a DC voltage, the 'I' core will be attracted to the 'U' core. Feel how strongly the cores are attracted. Try to pull them apart. Using a steady voltage of say 4 to 6 volts DC, compare the DC current flowing through the coil when it has:

- **No iron core fitted.**
- **Only the 'U' core fitted.**
- **With 'U' core and solid iron bar 'I' core positioned.**
- **With 'U' core and laminated 'I' core positioned.**

Notice that there is no change in the DC current that creates the magnetic field. The steady magnetic field with or without iron has no effect on the coil's resistance.

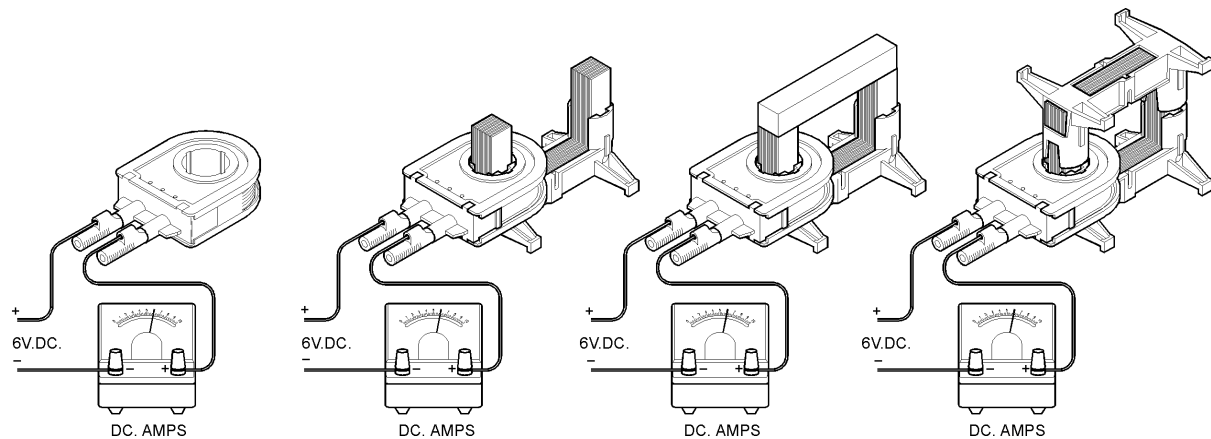

61) MEASURE AC MAGNETISING CURRENT:

AC is used if the device is to transform. The 'I' core will be attracted to the 'U' core to create an AC electro-magnet, but when pulled apart, the noise of the 100 magnetic pulses per second can be heard and felt on the hand. Now, using say 12V.AC on the primary, compare the AC current flowing through the coil when it has:

- **No iron core fitted (apply for very short time only).**
- **Only the 'U' core fitted (for short time only).**
- **With 'U' core and solid iron bar 'I' core positioned.**
- **With 'U' core and laminated 'I' core positioned.**

Notice that there is a great change in the AC current that creates the magnetic field. A properly designed transformer tries to keep the magnetising current to a minimum.

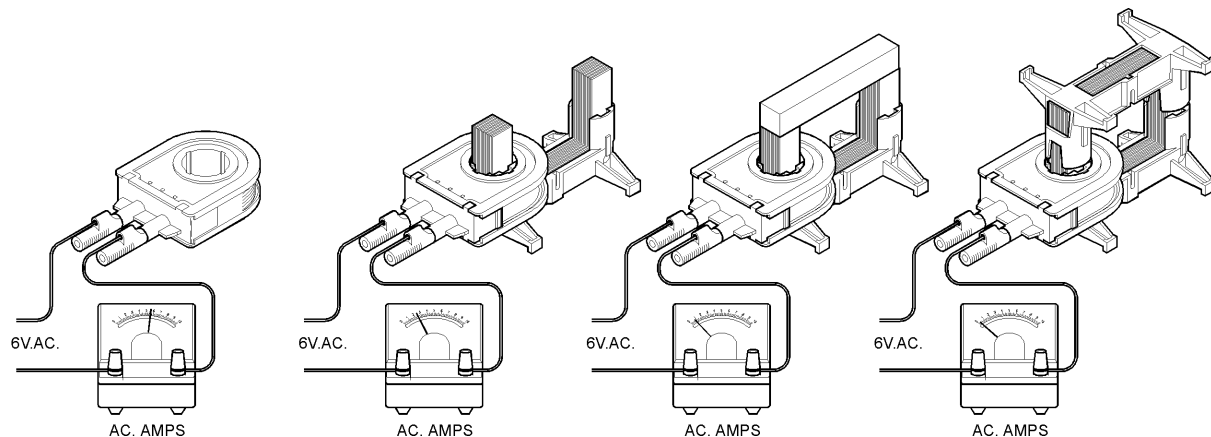
The lowest current is achieved when the iron core is fully closed and when the iron is all laminated.



62) Connect coils in different ways to obtain different voltages:

Series or Parallel connections:

See the images below to learn the difference between series and parallel connections. Assuming primary of 300 turns connected to 12V.AC. Assuming 2 secondary coils wound at 100 turns. If the primary is connected to 12V.AC, each secondary will deliver close to 6V.AC. The images show the Start and Finish of the coils to make the connection and result more obvious.

- If secondary coils in series and 'in phase', voltages add.
- If secondary coils in series and 'out of phase' (one coil reversed to the other), voltages subtract. Result zero.
- If secondary coils in parallel and 'in phase', voltage unchanged but double current available.
- If secondary coils in parallel and 'out of phase', a large current flows between them and they get hot. Voltage will be zero. **CONNECT LIKE THIS ONLY FOR A SHORT TIME.**
- Wind and fit a coil with 50 turns and try connecting to buck and boost the voltages.

The following images provide various simple examples of transformer connections. Try them and check the results. Work out some connections for yourselves and maybe connect up 2 separate transformers to one another.

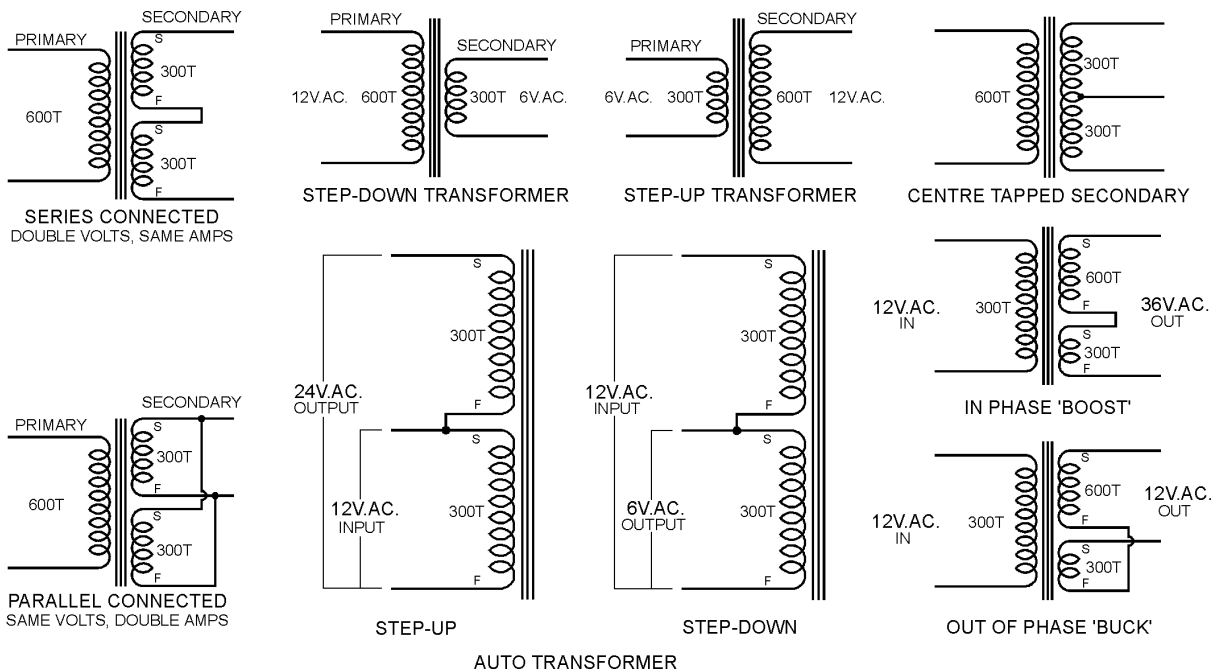

An 'Auto Transformer' has only one winding and a tapping part way along, or it can be formed by using two coils joined in series as shown above. If 12V.AC is applied to one coil, 24V.AC will appear across both. If 12V.AC is applied across both, 12V.AC will appear across one coil. Coils can be a different number of turns and the voltages will vary accordingly.

A major difference with this type of transformer is that the output voltage IS CONNECTED electrically to the applied voltage. It is NOT an 'Isolating Transformer'. Transformers like this are often used to transform the 240V.AC as used in Australia to say 110V.AC as used in America when an American machine must be used from Australian mains power.

63) THOMPSON'S RING EXPERIMENT:

Place the 'U' core on the table with the 300 turn primary coil fitted to one leg. Stand the long iron bar on the SAME leg so it is extended vertically upwards.

Place the 'Thompson's Ring' over the core so it rests on the top face on the primary coil bobbin.

Apply 12V.AC to the primary coil and watch the ring. Try different voltages.

Try DC instead of AC and see what happens. Explain.

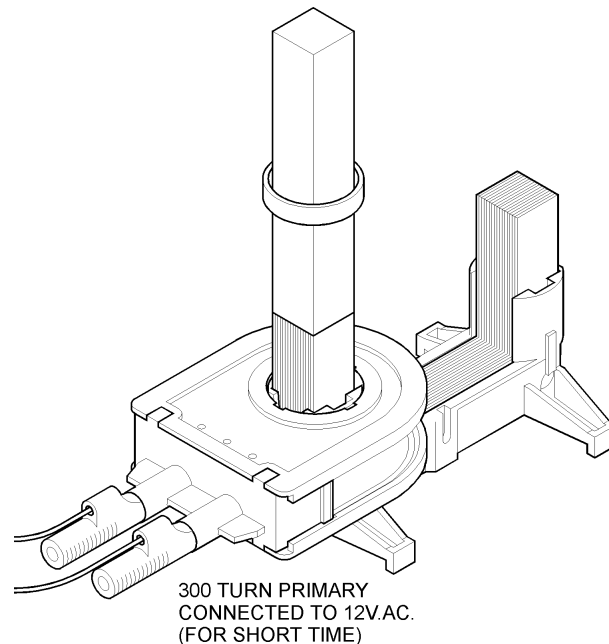

When AC is used, the ring jumps upwards and floats in the magnetic field. **WHY ?**

The ring behaves as a secondary coil with only one turn that is **short circuited** and therefore carries a very high current. This current creates a strong magnetic field around the ring in opposition to the applied field in the primary coil. This force pushes the ring away from the coil until the force balances against the weight of the ring. When the weight and the force equals, the ring 'hovers' in the field.

CAUTION:

- 1) The large current in the ring can make the metal ring very hot. Be careful not to burn your fingers on the ring.
- 2) The primary coil is running without a closed magnetic core and you know this causes a very high magnetising current. If run for too long, the coil winding will get very hot.

Try rings made from copper wire or pieces of metal tube. Try different metals and explain the effects.

Wind a secondary coil with just a few turns and short circuit the coil (twist the Start and Finish together tightly). Place it on top of the primary coil. Be careful of any heat generated in the winding.



'MINI WAVE' SIGNAL GENERATOR - digital

using 'DIGITAL SYNTHESIS'

HIGH POWER

Cat: LB3753-101 220/240V.AC. 50/60Hz. 0.1 Hz – 99,999 kHz. 1 amp

DESCRIPTION:

The general purpose **IEC Digital Signal Generator** is a very easy to use, compact, microprocessor driven, super-accurate, and super-stable instrument for the Physics and Electronics laboratory. The interface is a large 5 digit red LED display. This excellent unit is a broad range, high current instrument and the selectable waveforms are: **sine, triangular, sawtooth and square** in shape. It provides high currents up to 1 amp directly to loads at up to 15V peak to peak which makes the use of amplifiers unnecessary.

NOTE: 15V p/p is equivalent to 5V RMS (AC effective volts).

This instrument can directly feed a loud speaker, solenoid, vibrator or other electro-mechanical device requiring heavy current. Experiments on low frequency oscillations and waves can be devised using the mechanics of a large loud speaker as the driver.

THE IEC 'QUICK SET' system is used and the simple controls are:

Digit SELECT button, increase (UP button), decrease (DOWN button), WAVEFORM select button and knob for OUTPUT from 0 to 5V.RMS (effective). Output sockets are 4mm safety type and current is limited to a maximum of 1 amp.

LB3753-001 digital signal generator (high power, 1 amp)



Physical size: very compact 170x125x80mm LxWxH Weight: 0.97 kg.

**INSTRUCTIONS FOR USING THE INSTRUMENT:**

Turn on power switch at the rear of the instrument. When ON, the red LED digits will be on. Use the knob to alter the output voltage up to 5V.AC. RMS max (15V p/p max). All zeros to the left of a value are automatically blanked.

To set frequency of say 500.0 Hz, proceed as follows:

- **Press the DIGIT button. All digits illuminate and the left digit will be much brighter than the others. This is the active digit. The waveform indication will turn off.**
- **Press the DIGIT button once to brighten the 4th digit from the right.**
- **Press the UP or DOWN buttons to set '5' on this digit and note that if held depressed, the digits continue to automatically increment or decrement.**
- **Then press the DIGIT button to select the next digit and press the DOWN button to reduce each digit to zero (if necessary) until you see 500.0 Hz. The output will be delivering this frequency.**
- **Press the DIGIT button until you have passed beyond the right hand digit. The display will return to normal brightness and the waveform indication will be on.**
- **To alter this frequency to 728.3 Hz, press the DIGIT button until the '5' is bright. Press the UP button to set value '7'.**
- **Press the DIGIT button again to step one digit to the right. Press the UP or DOWN button to set value '2'.**
- **Press DIGIT button to step one more digit to the right. Press UP to set value '8'.**
- **Finally, press the DIGIT button to step to the extreme right digit. Press the UP or DOWN buttons to set value '3'. The output will be 728.3 Hz.**
- **Press the DIGIT button one more time to pass from the display and all the digits will return to normal brightness and the waveform indication will be on.**

ADJUSTING THE DIGITS: "quick-set" system

- **With any digit, if the value is increased beyond 9, the digit will change to zero and the digit to the left will increase by 1... as expected.**
- **If any digit is reduced below zero, the digit will change to 9 and, if there is a digit to the left, it will be reduced by 1... as expected. When selections are finished, all zeros to the left of the first value are blanked as the waveform indication appears.**

OUTPUT RESOLUTION: At 0.0 Hz: The output can be used as a well protected DC power supply, adjustable from zero to 7.5V.DC. at 1 amp output.

From 0.1 Hz to 10 kHz: Any frequency from 0.1 Hz up to 9999.9 Hz can be directly set on the display with a resolution of 0.1 Hz.

From 10 kHz to 100 kHz: If the extreme left digit is increased beyond 9, the decimal point disappears and the digits all shift to the right to provide a 5 digit display without decimal. The maximum frequency is 99999 Hz and the resolution is 1 Hz.

**SPECIFICATIONS:**

Input:	220/240V.AC. 50/60 Hz. Approx. 0.2 amp.
Frequency:	Very wide range: 0.1 Hz. to 99,999 Hz.
Fast adjustment:	Button selects digit, then change digit UP and DN (0-9).
Display:	Large red LED 5 digit display.
Accuracy & Stability:	Crystal accuracy Error: up to approx 0.01%
Waveforms:	Sine, Triangular, Sawtooth and Square wave.
Voltage output:	Adjustable from 0 to 15V peak to peak (0 to 5V.RMS)
Current output:	Automatic limit, 1 Amp max. into any load or short circuit.

A FEW USES:

- **Signal source for any Electronics Kit and for many experiments.**
- **A regulated DC power supply, 0 - 7.5V.DC. at 1 amp.**
- **For a signal source for the IEC Kundt's Apparatus tone generator.**
- **For demonstrating features of an Oscilloscope.**
- **For running vibrators (Melde's apparatus etc.) and loud speakers.**
- **For speed of sound experiments in air and solids.**
- **For determining resonance in inductive and capacitive circuits.**
- **For the study of reactance in AC circuits..... and so on**

NOTES:

1) Output voltage is controlled continuously from zero to 15 volt peak to peak. The output current is limited to 1 amp max. to prevent damage if the output is short circuited. If the load demands larger current, the current limiting feature will cause waveform distortion as the current rises beyond 1 amp. When connecting the output to very low impedance loads (less than 20 ohms), be sure that the output voltage is set so as not to exceed 1 amp load current.

2) The output voltage can be controlled smoothly from zero to 15V peak to peak on the output but since the output is automatically current limited, a short circuit on the output will draw 1 amp but will not damage the instrument.

3) IEC produces also a triple function instrument that includes a +/- regulated DC power supply and a very useful audio amplifier with speaker all in the one compact housing. This instrument is named the 'TRI-MODE'. Cat: LB3758-001

Mains Input: 220/240 V.AC. 50/60 Hz.. 0.2A max.

Protection: Electronic overload protection.

Designed and manufactured in Australia

A.C. EXPERIMENTS USING THE MINI-WAVE SIGNAL GENERATOR

64) Measure DC resistance of a Resistor using a multimeter (ohm meter).

Equipment required:

- 1x digital multimeter
- 1x resistor, 50 ohms.
- 2x cables with banana plugs

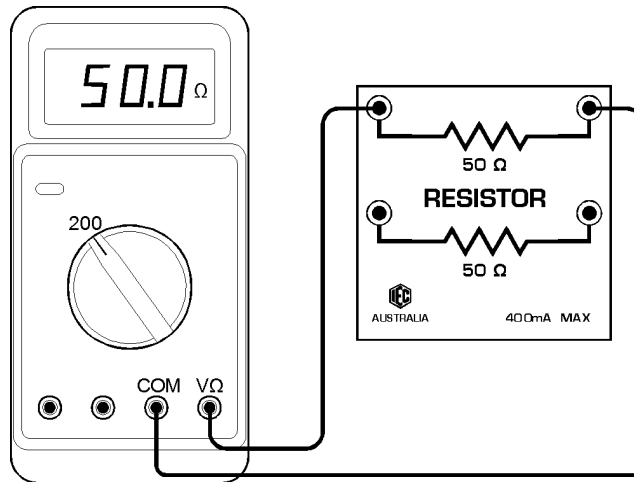
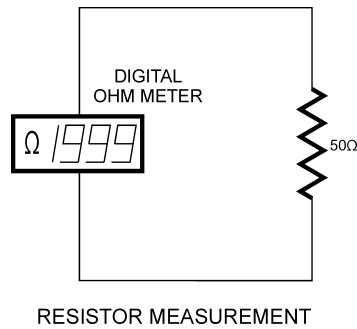

Connect the circuit as shown, select the correct range to suit the expected value and read the value of the resistance on the meter in ohms. Note how close this value is when compared to the 25 ohms marked on the resistor housing. Calculate the percentage error.

65) Measure the DC Resistance of an Inductor.

Equipment required:

- 1x Inductor
- 1x digital multimeter
- 2x cables with banana plugs

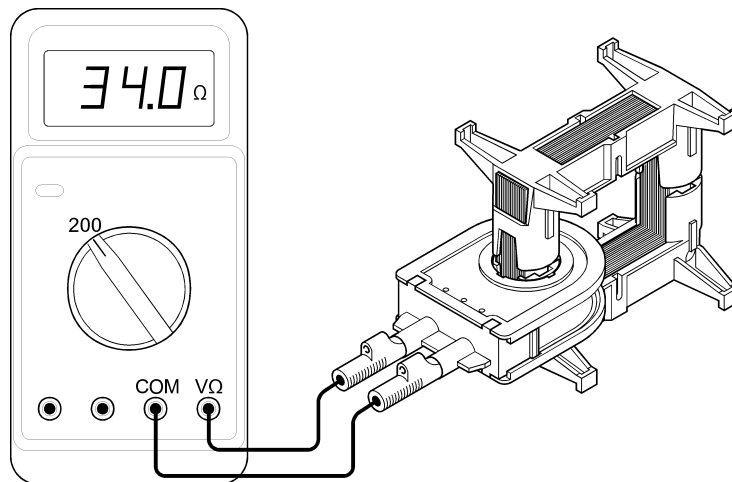
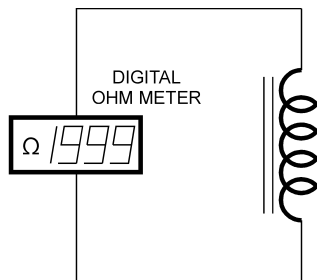

Connect the circuit as shown and read and note the resistance of the Inductor in ohms. This measurement is the resistance of the large coil of copper wire wound around the Inductor's iron core. This value will change a small amount depending on the temperature of the copper wire. The multimeter applies DC voltage to the coil to measure the resistance, so this resistance can be called the DC resistance.

Any heat generated in this wire is caused by the resistance of the wire and the current flowing through it. $Power = Amps^2 \times Resistance$. This heat would be wasted power from the Inductor. For best efficiency for the Inductor, the resistance of the coil is kept to a minimum to keep power losses to a minimum.

66) Measure AC resistance using AC volts and AC amps.

Equipment required:

- 2x digital multimeters
- 1x signal generator
- 1x resistor, 50 ohms.
- 5x cables with banana plugs

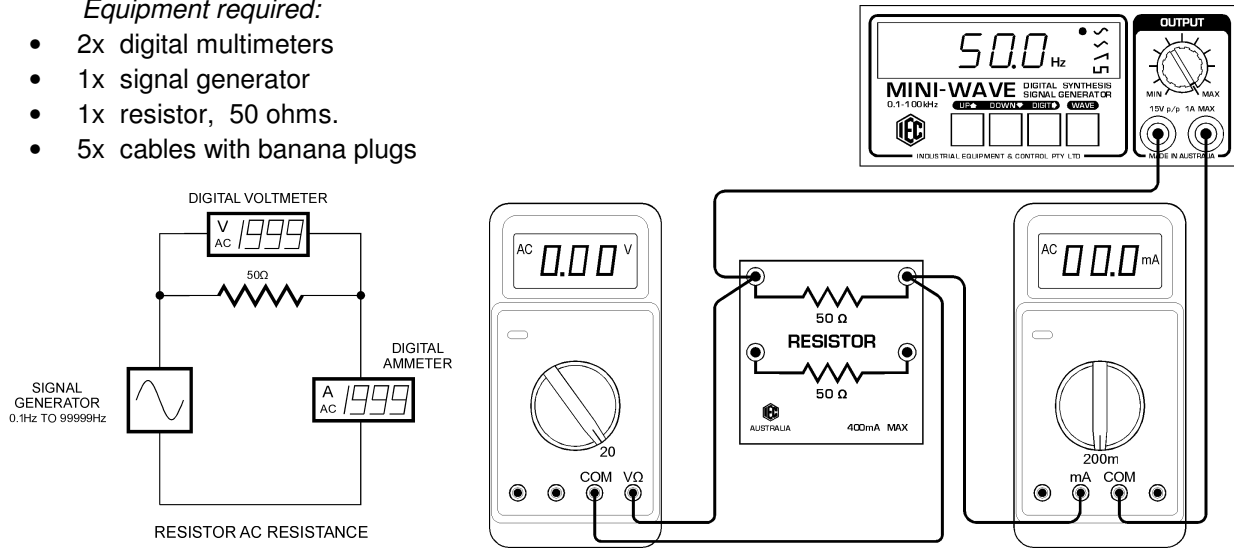

Connect the first circuit as shown and set the signal generator to 50.0 Hz sine wave.

Use the AC volts range on the digital multimeter to measure and note the output voltage on the signal generator. This voltage is the RMS value (or the effective value) of the sine wave voltage shape. Check the 'Glossary' to check the meaning of 'RMS'. Note this voltage.

Connect the multimeter set to AC amps in series with the resistor and measure and note the AC current flowing. This is the RMS value (or the effective value) of the sine wave current shape (see later experiment and the Glossary for explanation of RMS). Note this current.

Resistance = Volts / Amps. Divide the RMS volts reading by the RMS amps reading and compare the value of resistance in ohms with the measured value of experiment 1).

If we could measure the instantaneous reading of the volts and the amps, we would find that the dividing of the instantaneous volts by the instantaneous amps, the instantaneous resistance value would be exactly the same.

NOTE:: The reason 50.0 Hz was chosen as the frequency to be used is that some digital meters are designed to measure accurately at around 50 to 60Hz and they are less accurate at other frequencies.

Repeat the experiment at 25.0Hz and also at 100Hz and 200 Hz. Is there a variation in your meter measurements that is caused by these different frequencies ?

Does resistance change with frequency ?

You have measured the resistance using different frequencies.

You have discovered that a change in frequency does NOT change the ohms value of the resistor.

67) Measure the Impedance of an Inductor:

Equipment required:

- 1x Inductor
- 1x signal generator
- 2x digital multimeters
- 5x cables with banana plugs

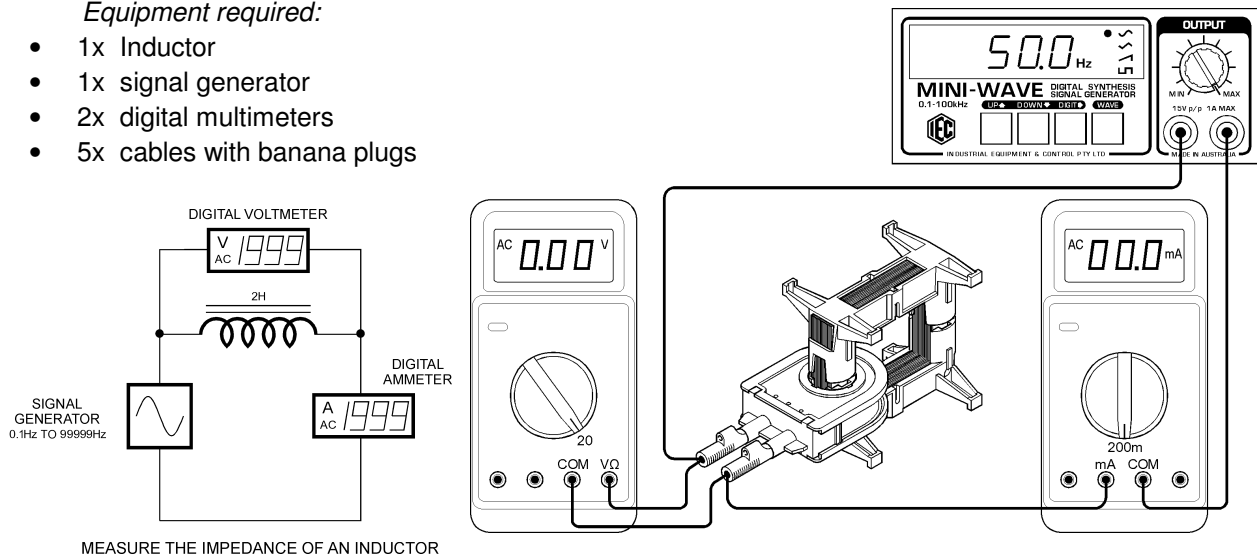

Connect the circuit as shown and set the frequency of the signal generator to Sine wave and 50.0Hz. Set the multimeter to AC volts and measure and note the voltage from the signal generator. Set the second multimeter to AC amps and connect it in series with the Inductor to measure the AC current flowing through the Inductor.

Calculate the Impedance (Z) by dividing the AC volts by the AC amps. $Z = V / A$

Notice that the Impedance (ohms) is a much higher value than the Resistance (ohms) as measured in the previous experiment.

The copper wire is the same copper wire you measured before in Ohms. Explain why the value of 'AC resistance' in Ohms as calculated by AC volts and AC amps is much higher than the value of 'DC resistance' in Ohms as measured by the multimeter. Refer to the Glossary of Terms to find the description of 'Impedance'.

CHANGE FREQUENCY:

Now alter the frequency of the signal generator to say 25Hz and note the AC current flowing. Measure the AC current flowing and calculate the Impedance (Z ohms) as above.

Now alter the frequency to 100Hz and note the AC current flowing. Measure the AC current flowing and calculate the Impedance (Z ohms) as above.

It can be seen that the Impedance of an Inductor increases as the frequency of the AC Sine wave increases. This means that the formula for Impedance of an Inductor must include the frequency as one of the direct factors.

Repeat the experiment at frequencies of say 20Hz increments from 30Hz up to 200Hz. Calculate the Impedance at each frequency.

Using graph paper, create a graph of frequency (on the X axis) to Impedance in ohms (on the Y axis). Note that a straight line graph is the result. This means that the impedance of an inductor changes linearly and directly with frequency.

Notice that the graphed line is not pass through the Zero point. As the graph is extended to be on zero frequency, what is the displacement in ohms from the zero point ?

Does this value of ohms equal something ?



68) Measure the Reactance of an Inductor:

The Impedance is a combination of the DC resistance of the coil plus another type of resistance that changes with frequency. This type of 'AC resistance' is called Reactance. The symbol for reactance of an Inductor is ' X_L ' and the unit is ohms. Impedance Z ohms = R ohms + X_L ohms.

Now to find the reactance of the inductor, subtract R ohms from each of your Impedance readings and plot another graph of X_L ohms against frequency.

Notice that the graph will pass through the zero point when the frequency is zero.

The difference between this graph and the impedance graph is the DC resistance value of the coil of wire that forms the Inductor.

Is this difference significant ?

WHERE DOES INDUCTIVE REACTANCE COME FROM ? refer to the Glossary.

Explanation 1): We know from our basic DC theory that when current passes through a wire, a magnetic field is created around the wire. We know also if a magnetic field passes across a wire, a voltage is generated in the wire while the lines of magnetic force are crossing it. If the magnetic field is passing the wire quickly a higher voltage is created in the wire then when it passes slowly.

In the case of an AC voltage applied to a coil of many turns wound on an iron core, the voltage applied to the coil is rising, falling and reversing repetitively in a Sine wave shape. This means that the magnetic field in the iron core is also constantly growing and shrinking and reversing also in a Sine wave shape. This growing and shrinking of the magnetic field cuts all the turns of the coil in both the forward and reverse directions many times per second – depending on the frequency of the AC wave.

This cutting of the turns in the coil generates a voltage which, at any instant through each Sine wave, is in reverse to the applied voltage. If, for example, 10 volts AC is applied to an inductor, the reverse voltage might be equal to about 9 volts AC. This means that the resulting current flowing through the coil would be equivalent to only 1 volt being applied to the coil. This small current flowing, even though 10 volts is applied to the coil, APPEARS TO BE an increase in resistance of the coil.

Explanation 2): As an AC voltage is applied to an inductor, the current rises through the coil later, in real time, than the voltage. The voltage and the current are NOT 'in phase'. This is caused by the induced voltage in the coil caused by the current flowing through it. It causes the current to rise gradually and to LAG behind the applied voltage.

At any instant through the sine wave, the dividing of the instantaneous voltage by the instantaneous current gives an instantaneous resistance which is much higher value than the DC resistance of the coil.

This APPARENT increase of resistance is called the Reactance of the coil at that particular frequency and it will change with the frequency applied to the coil. In the case of an Inductor, the reactance (X_L ohms) increases with frequency as seen on your graph.

The Reactance depends also on the Inductance (L in Henrys) of the inductor which is dependent on the number of turns of the coil and the amount of iron in the magnetic circuit. If a coil has many turns and a large iron circuit, its Inductance is large.

**69) Measure the Inductance of an Inductor:****FORMULA:**

For an Inductor, **Reactance $X_L = 2\pi fL$** Where ' X_L ' is the reactance in ohms, ' f ' is the frequency of the Sine wave in Hertz (or cycles per second) and ' L ' is the Inductance of the inductor in Henrys.

Using the figures from the different frequencies and the different values of Reactance from the previous experiment, use this formula to calculate the Inductance of the Inductor in Henrys.

$$L = X_L / 2\pi f \text{ Henrys}$$

CAPACITORS:**70a) The resistance of a Capacitor:**

The series resistance of capacitors is usually small and the value is difficult to measure. Special electronic instruments are available to measure the resistance of capacitors but they do not use first principles.

Typically, a capacitor could have a series resistance of between 0.1 ohms and 3 ohms. This resistance is an unwanted feature of capacitors because it generates heat in the capacitor as the current through it rises. The resistance value of a capacitor rises as the capacitor temperature rises and this, together with other factors, often limits the ambient temperature in which capacitors can be used and the currents that capacitors can carry.

This kit is not able to directly measure the series resistance of a capacitor, however the resistance in ohms can be seen graphically at the end of the next experiment relating to Impedance.

70b) Measure the Impedance of a Capacitor:

Equipment required:

- 1x Capacitor 5uF
- 1x signal generator
- 2x digital multimeters
- 5x cables with banana plugs

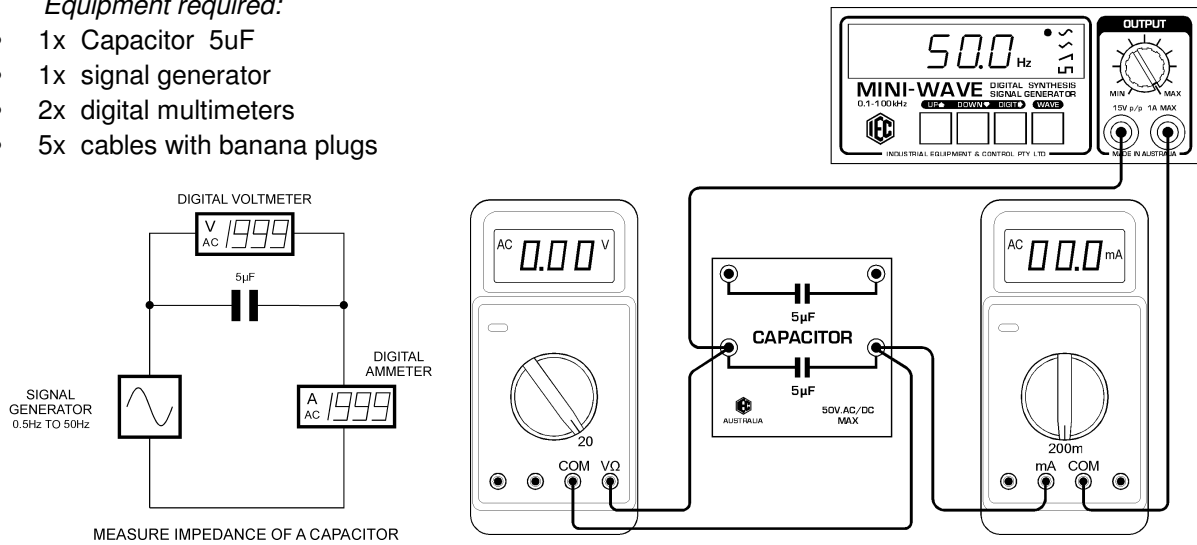

Connect the circuit as shown and set the frequency of the signal generator to Sine wave and 50.0Hz.

Set the multimeter to AC volts and measure and note the voltage from the signal generator.

Set the second multimeter to AC amps and connect it in series with the Capacitor to measure the AC current flowing through the Capacitor.

Calculate the Impedance (Z) by dividing the AC volts by the AC amps. $Z = V / A$

Notice that the Impedance (ohms) is a much higher value than the expected resistance of a capacitor as discussed in the previous experiment.

Explain why the value of 'AC resistance' in Ohms as calculated by AC volts and AC amps is much higher than the typical value of 'DC resistance' in Ohms as suggested in the previous experiment. Refer to the Glossary of Terms to find the description of 'Impedance'.

CHANGE FREQUENCY:

Now alter the frequency of the signal generator to say 25Hz and note the AC current flowing. Measure the AC current flowing and calculate the Impedance (Z ohms) as above.

Now alter the frequency to 100Hz and note the AC current flowing. Measure the AC current flowing and calculate the Impedance (Z ohms) as above.

It can be seen that the Impedance of a Capacitor decreases as the frequency of the AC Sine wave increases. This means that the formula for Impedance of a capacitor must include the frequency as one of the inverse factors.

Repeat the experiment at frequencies of say 20Hz increments from 30Hz up to 200Hz. Calculate the Impedance at each frequency.

Using graph paper, create a graph of frequency (on the X axis) to Impedance in ohms (on the Y axis). Note that a straight line graph is the result. This means that the impedance of a capacitor changes linearly and inversely with frequency.

Notice that the graphed line is not pass through the Zero point. As the graph is extended to be on zero frequency, what is the displacement in ohms from the zero point ?

Does this value of ohms equal something ?



71) Measure the Reactance of a Capacitor:

The Impedance is a combination of the DC resistance of the capacitor plus another type of resistance that changes with frequency. This type of 'AC resistance' is called Reactance. The symbol for reactance of a Capacitor is 'Xc' and the unit is ohms. Impedance $Z \text{ ohms} = R \text{ ohms} + Xc \text{ ohms}$.

Now to find the reactance of the capacitor, subtract R ohms from each of your Impedance readings and plot another graph of Xc ohms against frequency.

Notice that the graph will pass through the zero point when the frequency is zero.

The difference between this graph and the impedance graph is the DC resistance value of the capacitor.

Is this difference significant ?

WHERE DOES CAPACITIVE REACTANCE COME FROM ? refer to the Glossary.

We know from our basic DC theory that a capacitor consists of metal plates with an insulation material between them. Current cannot pass directly from one metal plate to the other. When a voltage is applied to the capacitor plates, a current passes to the plates to create a CHARGE equal to the applied voltage. This DC current is momentary as the plates become charged.

When a AC voltage is applied to a capacitor, since the applied voltage is rising and falling and reversing many times per second, the charging current is passing into and out of the plates repetitively thus causing an AC current to flow. The plates are constantly charging and reversing their charge attempting to make the voltage between them equal the applied voltage at any instant.

In the case of a Resistor, the resistance at any instant of the Sine wave is exactly the instantaneous voltage divided by the instantaneous current flowing and the current flows at exactly the time as the voltage is applied. Therefore the AC resistance of a pure resistor is, at any instant inside the Sine wave, the same as the DC resistance of the resistor.

In the case of a Capacitor, since the voltage on the plates is created by the charging current flowing into them, the current flowing into a capacitor is, in real time, ahead of the voltage across the plates. The voltage and the current Sine waves are not rising and falling at the same time. In other words, they are not 'in phase'.

If the instantaneous value of the voltage is divided by the instantaneous value of the current, the instantaneous value of the 'equivalent resistance' is not the same as a resistor. In addition, the faster the applied voltage changes, the faster the current passes in and out of the capacitor plates. This faster current flow equates to a larger current flowing. If a larger current flows, this means that the 'equivalent resistance' is falling and there APPEARS TO BE a reduction of the resistance of the capacitor.

This equivalent resistance is called Capacitive Reactance and has the symbol '**Xc**' with a unit of **Ohms**. It reduces in value with an increase in frequency of the applied voltage as seen on your graphs.

The Reactance depends also on the Capacitance (C in Farads) of the capacitor which is dependent on the area of the metal plates and the thickness of the insulation between them. If a capacitor has large plates and a very thin insulation between them, its Capacitance is large.

**72) Measure the Capacitance of a Capacitor:****FORMULA:**

For a Capacitor, **Reactance $X_c = 1 / 2\pi fC$** Where ' X_c ' is the reactance in ohms, ' f ' is the frequency of the Sine wave in Hertz (or cycles per second) and ' C ' is the Capacitance of the capacitor in Farads.

Using the figures from the different frequencies and the different values of Reactance from the previous experiment, use this formula to calculate the Capacitance of the Capacitor in Farads. How close is your result to the Capacitance in microfarads (μF) marked on the Capacitor ?

$$C = 1 / (2\pi f \times X_c) \text{ Farads}$$

Exercise:: Graphs

Using data from previous experiments, plot graphs of the following:

- **Resistance of a pure Resistor against Frequency**
- **Reactance in Ohms of an Inductor against Frequency**
- **Reactance in Ohms of a Capacitor against Frequency**
- **Sine wave of voltage and current for a resistor on AC. The Current and Voltage are in phase. Calculate several instantaneous values of resistance at different places along the sine wave graph (volts / amps).**
- **Sine wave of voltage and current for an Inductor on AC. The Current lags the Voltage by 90° . Then, using several instantaneous values of Inductive Reactance ('AC resistance') at different places along the sine wave graph (volts / amps), plot the AC Reactance.**
- **Sine wave of voltage and current for a Capacitor on AC. The Current leads the Voltage by 90° . Then, using several instantaneous values of Capacitive Reactance ('AC resistance') at different places along the sine wave graph (volts / amps), plot the AC Reactance.**

73) Capacitors in series and parallel:

Equipment: 2x Capacitors 1x signal generator 2x digital multimeters 6x cables with banana plugs
 Connect circuit with one capacitor as shown below. Set the Signal Generator to a frequency of 50 Hz and measure the current flowing and the voltage across the capacitor.

Refer to earlier data or re-calculate the Capacitive reactance in ohms by subtracting the DC resistance from the Impedance. Note the reactance in ohms.

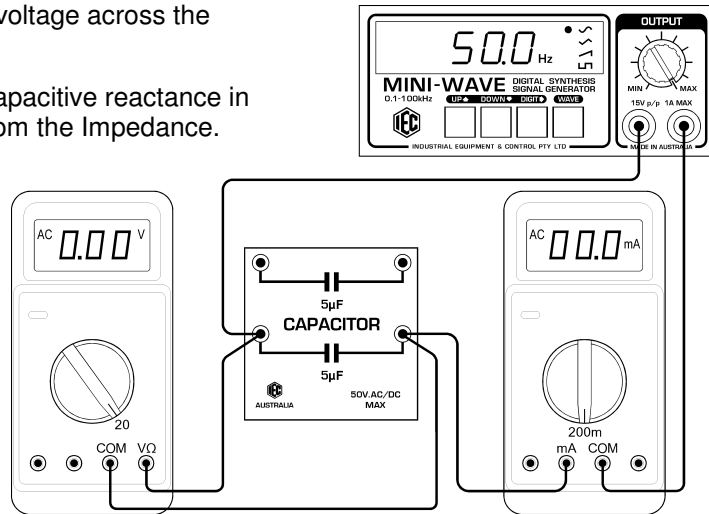
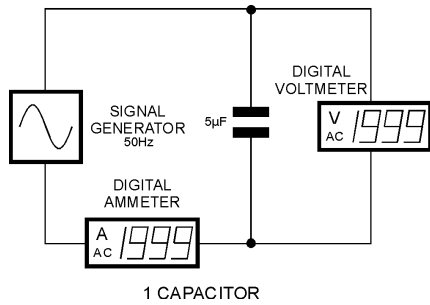

Now connect the 2 Capacitors in series as shown below and again measure the current flowing and voltage across the capacitor. Now calculate the new Reactance.

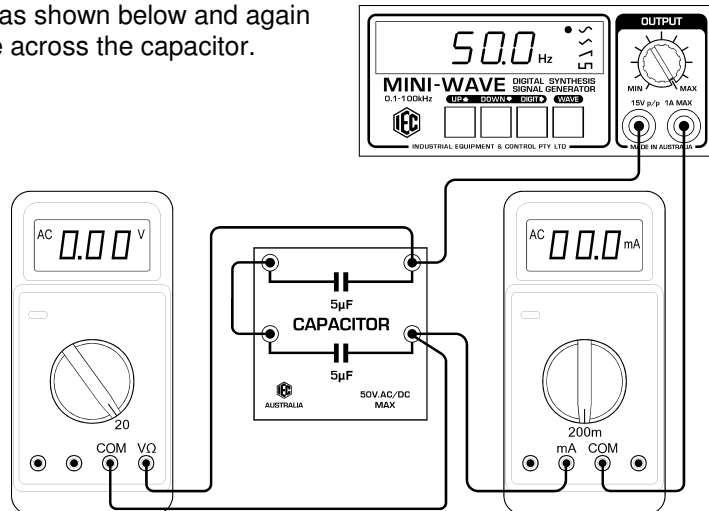
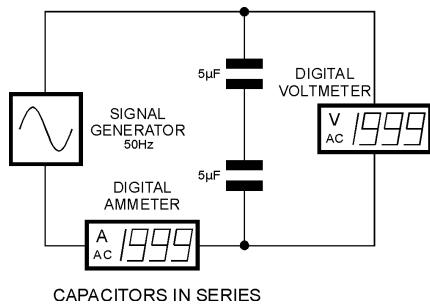

Now connect the 2 Capacitors in parallel and again calculate the new Reactance.

Since $X_c = 1 / 2\pi fC$, if the Reactance has changed, then the capacitance also has changed INVERSELY by the same proportion because the frequency and pi are constant.

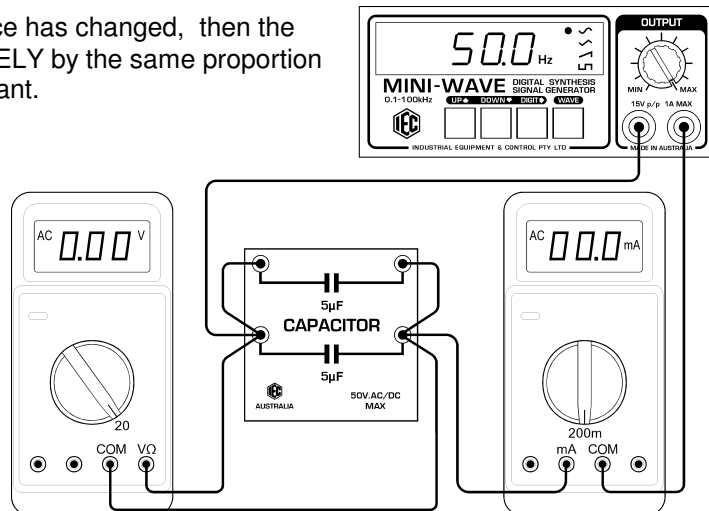
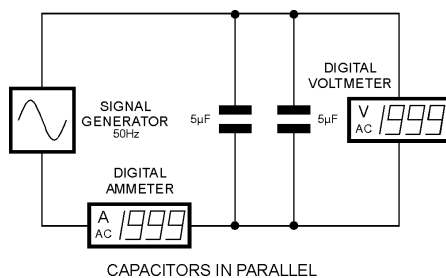

What is the rule you have discovered regarding Capacitors in series and in parallel ?

74) Resonance: Inductor and Capacitor in series:

Equipment required:

- 1x Inductor
- 1x Capacitor
- 1x Resistor
- 1x signal generator
- 2x digital multimeters
- 7x cables with banana plugs

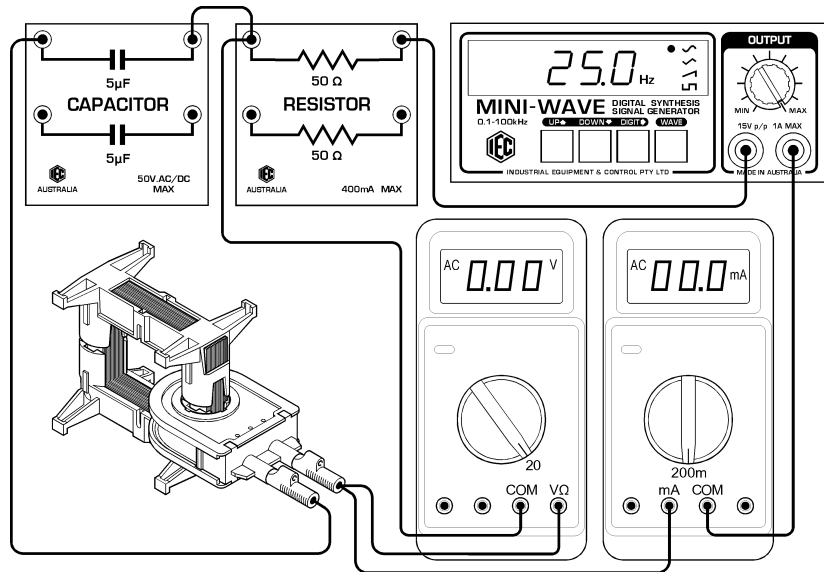
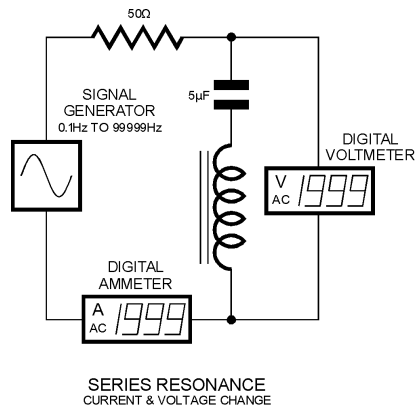

Connect circuit with a resistor in series with one inductor and one capacitor as shown above. Set the Signal Generator to a low frequency of say 10 Hz.

We know that as the frequency rises, the Inductive reactance increases and the Capacitive Reactance decreases.

We know also that the current in an inductor is 90° lagging the voltage and the current in a capacitor is leading the voltage by 90° . This means that the two currents must be 180° out of phase (opposing each other). So, it follows that when the two Reactances are the same and since both currents are opposing one another, the current flowing through the two in series should be ZERO and the AC voltage across the pair in series should be maximum.

The frequency at which this occurs is called the '**Resonant Frequency**' of the series circuit.

Monitor the voltage across the series pair and gradually increase the frequency. Note the frequency where the voltage is maximum. Increase the frequency further and notice the voltage. Readjust the frequency to obtain the maximum voltage.

Calculate the Reactance of the capacitor and the Reactance of the Inductor at this frequency.

What do you notice about the results ?

QUESTION: What is the purpose of the series resistor in this circuit.

CLUE: What would the voltage reading be at all times if the resistor was not there ?

75) Resonance: Inductor and Capacitor in parallel:

Equipment required:

- 1x Inductor
- 1x Capacitor
- 1x Resistor
- 1x signal generator
- 2x digital multimeters
- 8x cables with banana plugs

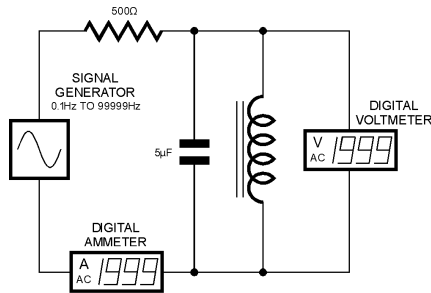

PARALLEL RESONANCE
CURRENT & VOLTAGE CHANGE

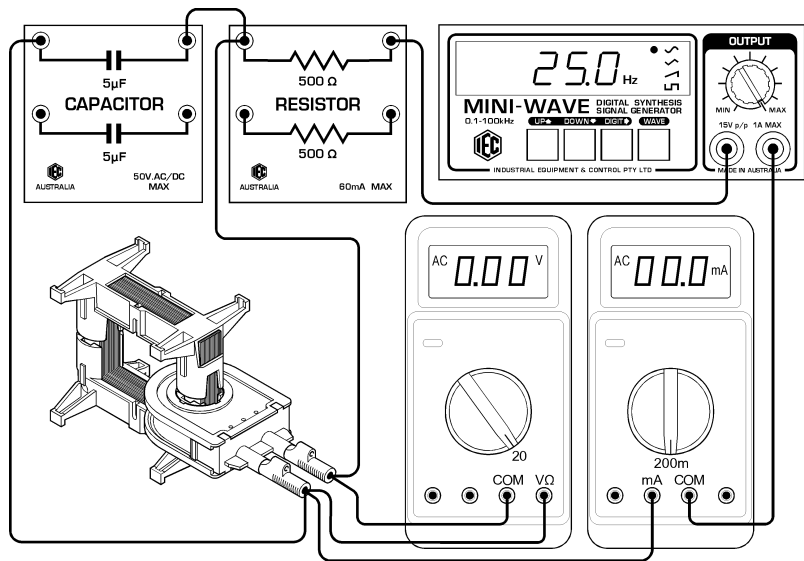

Connect circuit with a resistor in series with one inductor and one capacitor in parallel as shown above. Set the Signal Generator to a low frequency of say 10 Hz.

We know that as the frequency rises, the Inductive reactance increases and the Capacitive Reactance decreases.

We know also that the current in an inductor is 90° lagging the voltage and the current in a capacitor is leading the voltage by 90° . This means that the two currents must be 180° out of phase (opposing each other). So, it follows that when the two Reactances are the same and since both currents are opposing one another, the current flowing through the two in parallel should be MAXIMUM and the AC voltage across the pair in series should be minimum.

The frequency at which this occurs is called the '**Resonant Frequency**' of the parallel circuit.

Monitor the voltage across the parallel pair and gradually increase the frequency. Note the frequency where the voltage is minimum. Increase the frequency further and notice the voltage. Readjust the frequency to obtain the minimum voltage.

Calculate the Reactance of the capacitor and the Reactance of the Inductor at this frequency.

What do you notice about the results ?

QUESTION: What is the purpose of the series resistor in this circuit.

CLUE: What current would the signal generator need to supply if the resistor was not there ?

76) Power Factor:

Equipment required:

- 1x Inductor (300 turns)
- 1x Capacitor 5 μ F
- 1x Switch
- 1x Signal Generator
- 2x digital multimeters
- 8x cables with banana plugs

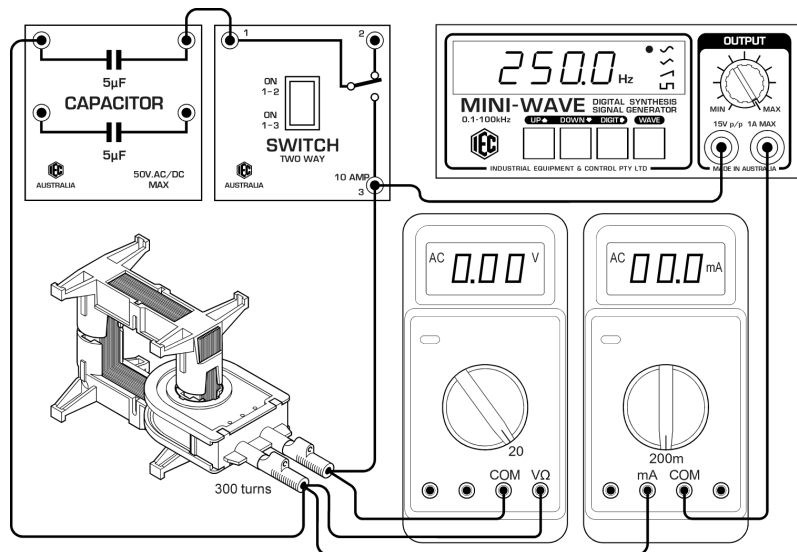
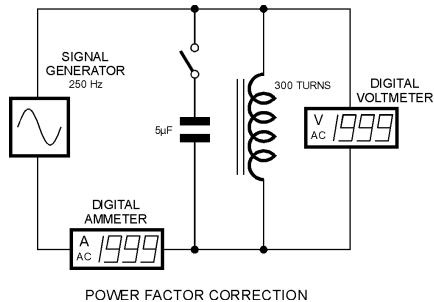

Connect circuit as shown above and set the signal generator to 250Hz. The switch permits the capacitor to be connected in parallel with the inductor. The two digital meters are measuring the circuit current and the voltage across the load.

WHAT IS POWER FACTOR ?

We know from basic theory that in a DC circuit, the multiplication of Volts x Amps = Watts of power. The same is true in an AC circuit where the load is purely resistance.

In AC circuits, the multiplication of Volts and Amps is not called Watts, it is called **Volt Amps**.

When an AC circuit has either Inductance or Capacitance, the power calculation is very different. Power Factor is a number that is mathematically the Cosine of the angle of Lead or Lag in an AC circuit. If the multiplication of volts and amps in an AC circuit is multiplied by the Power Factor, the actual usable power is the result. Formula is: Volt Amps x Cos (lead or lag) = Watts of power.

If the angle is 90° the resultant power is zero because $\text{Cos } 90^\circ = 0$. If the angle is zero, the resultant power is maximum because $\text{Cos } 0^\circ = 1$

Therefore it can be seen that to get the best power from a motor or other AC device, the smallest angle of lead or lag gives the best efficiency from the device. EXAMPLE: If an AC motor has a power output of say 1000 watts and runs on a voltage of 100 volts, the current should be 10 amps for best efficiency. BUT if the angle of lag is say 45°, the current will be 14.1 amps. You will be buying 14.1 amps from the power company and using 14.1 amp sized wiring etc but you will be receiving only 10 amps worth of power from the motor.

To generate usable power in an AC circuit, it is very important that the instantaneous volts and the instantaneous amps multiply together to form the largest positive going Sine wave of power. On your graph of current through an inductor, draw a power curve (also a sine wave) which is $V \times A$ at any point along the sine wave.

Draw the power curve on your graph of AC passing through a resistor. Note that when the voltage and current are in phase, the resultant power is a Sine wave that is always on the positive side of the Sine wave's zero line.

Now draw the power curve for your Inductor. When the current lags or leads the voltage by exactly 90°, the power curve as seen on your graphs is equal on both the positive and negative sides of the zero line, therefore the average power is zero.

**POWER FACTOR Cont'd:**

In a perfect Inductor, the DC resistance of the coil is zero and the iron circuit does not generate heat and the angle of lag is exactly 90° . Because power is zero, there is no heat generated by the perfect Inductor. The same theory holds for the perfect Capacitor.

In the case of the electric motor mentioned above, it is an inductive device, so to try to improve the Power factor (reduce the angle of lag) a capacitor is added in parallel to the inductive motor winding. This can be simulated in the circuit at the start of this experiment.

Now close the switch and add the capacitor into the circuit.

Notice that the current decreases while the voltage remains the same. This means that the leading angle of the capacitor has, to some degree, compensated the angle of lag and it is reduced from about 90° to a much smaller angle.

This technique of 'Power Factor Correction' is used very widely in industry to improve the efficiency of inductive machines like electric motors. It means that while obtaining the same power from the motors and paying the same money for energy (power used over time), the current drawn by the load is much lower. This saves on size of conductors, reduces heat losses in the conductors, switches and anything that must carry electric current. Large savings of many thousands of dollars can be made and power companies have a reduction to the current required to feed the electricity grid.

Designed and Manufactured in Australia



EXPERIMENT NOTES

MOTOR / GENERATOR SET – AC/DC, hand driven

Cat: EM1758-001 hand driven AC/DC motor/generator

DESCRIPTION:

The IEC hand driven Motor/Generator is a precision, ball bearing motor with a 2 pole rotor, a 2 bar commutator and 2x slip-rings. It can be run as a several types of DC and AC motors or can be hand driven to become a DC or AC generator. This kit contains::

- 1x DC/AC Motor/Generator with winder, belt, output terminals and LED monitors.
- 1x “U” shaped strong permanent magnet to create motor field.
- 1x Lamp load (2.5V 300mA) mounted to a circuit board for plugging into the terminals.

All parts of the motor are easily visible, the tension on the brushes is adjustable and the operation of the commutator and slip-rings can be studied. The commutator and slip-rings are self-lubricating to avoid squeaking and wear. The instrument is strong and is designed to have a long life in the hands of students. When connected as either an AC or DC generator, the MES lamp load will illuminate as electric power is created.

For the magnetic field through the motor, either the strong “U” shaped magnet can be used OR the Ucore that forms part of the IEC Electricity Kit EM1763-001, the IEC ‘Hodson’ Induction Kit EM1973-001 or the IEC Small Dissectible Transformer EM4089-001.

EM1758-001 hand driven AC/DC motor / generator

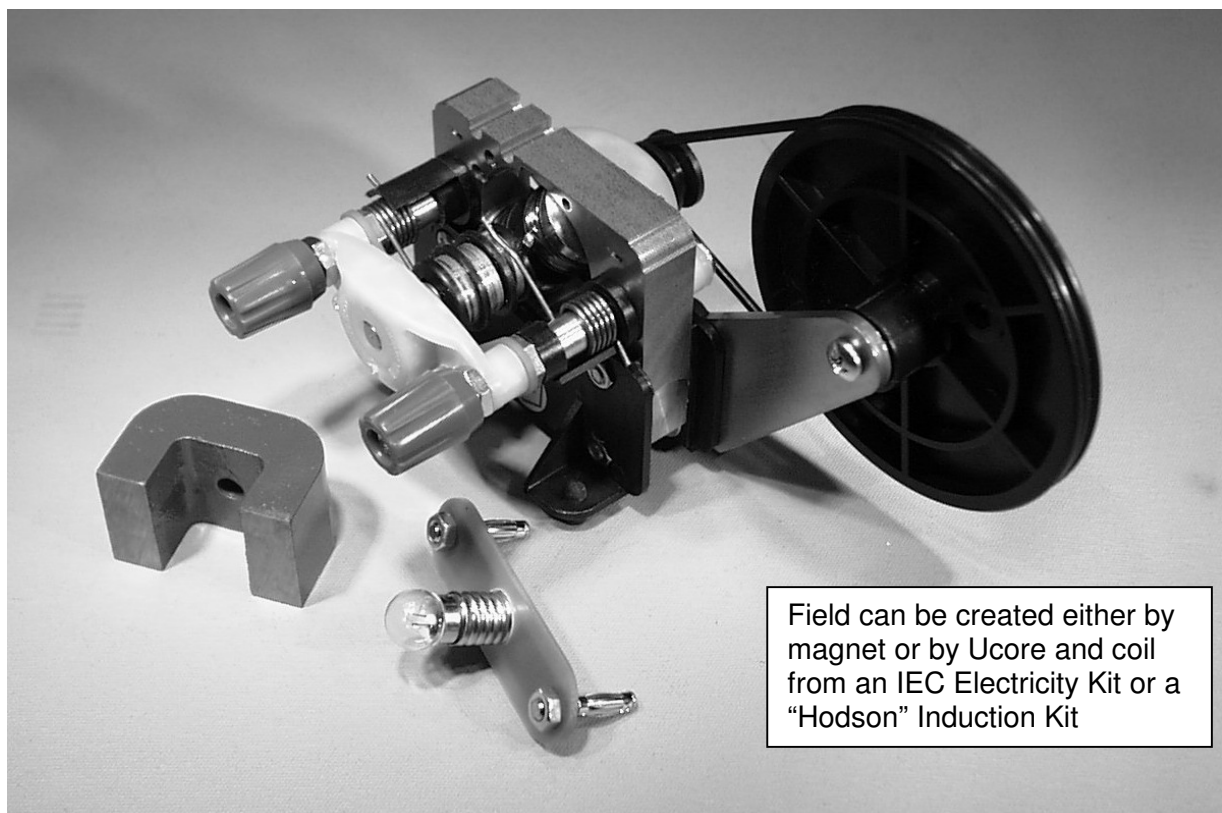

Physical size: 140x110x90mm LxWxH

Weight: 0.6 kg.

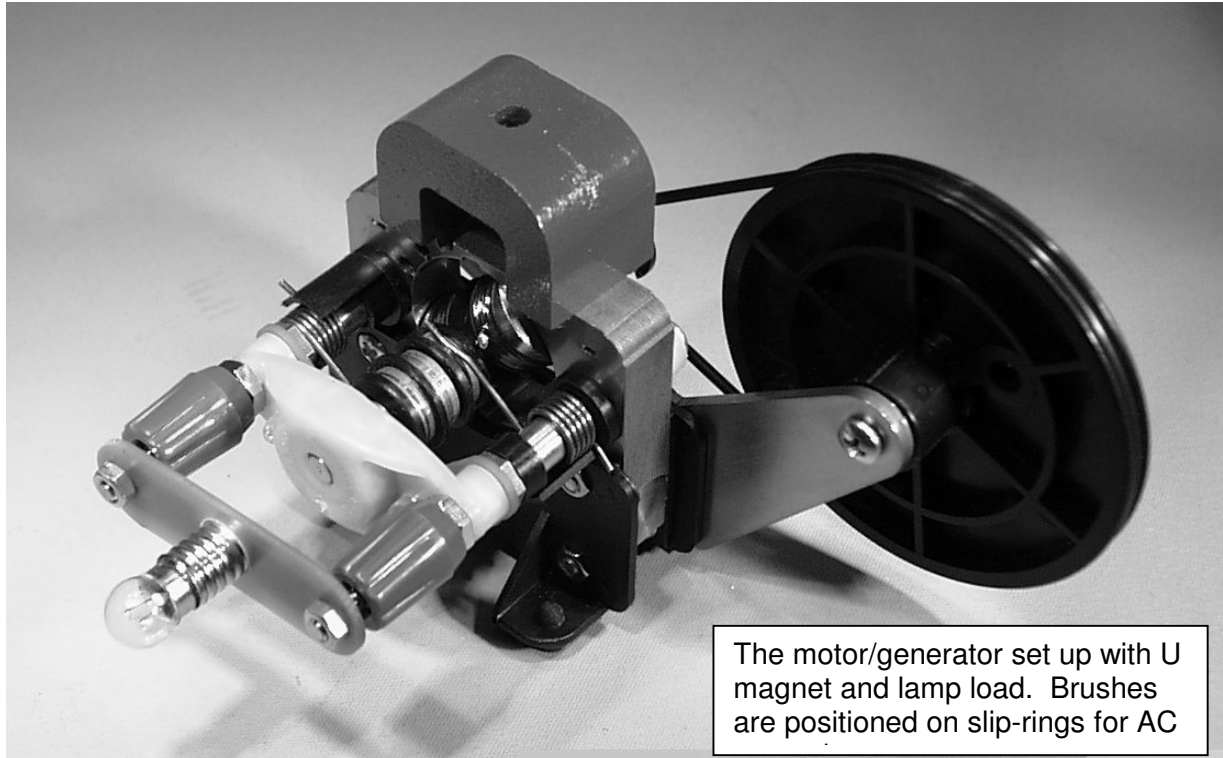

The motor can be used with the U magnet on top and the motor feet on the table. The red LEDs mounted in the end near the terminals indicate the positive polarity of the output. The image above shows the U magnet fitted, the brushes on the slip-rings (for AC output) and the lamp load plugged into the terminals. Red and Black has been avoided for the terminals because the output can be DC or AC depending on the brushes being positioned on either the commutator (middle ring) or the slip-rings (outer rings). See later in this document.

The iron core and coil image is not supplied as part of the IEC Motor/Generator but is part of the IEC Electricity Kit (EM1763-001) and is part of the "Hodson" Induction Kit (EM1973-001) or the IEC small Dissectible Transformer EM4089-001.

The Ucore and 300 or 600 turn coil is available separately as PA1973-010 + PA1973-026 or 027. The Motor unit slides between the legs of the Ucore and the coil connects to a power supply for a strong and adjustable AC or DC field to run the motor or generator. See images below.

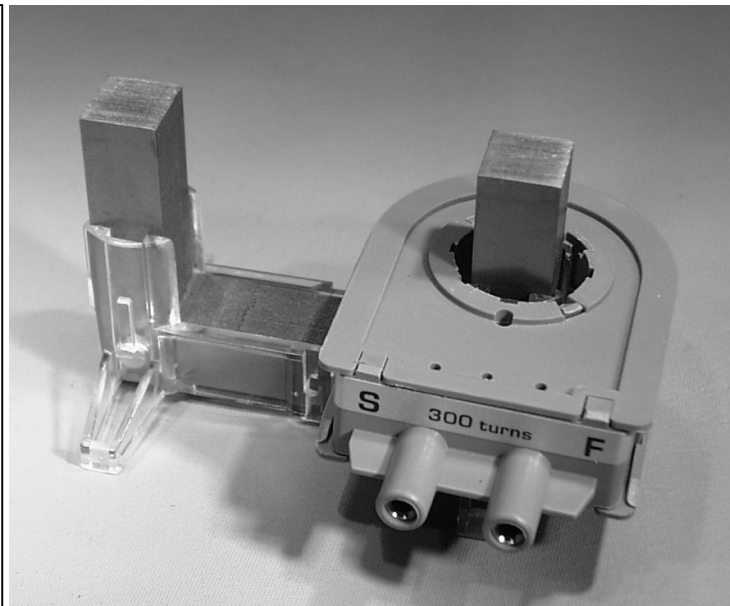

For the study of various types of DC/AC motors and generators, the U core and 300 or 600 turn coil is required. For basic DC motor /generator theory, the U magnet is sufficient.

For more advanced experiments, the Motor/Generator is slid into the Ucore and the coil is used to create a stronger and variable magnetic field for the motor.

When running as a motor, the belt can be removed or remain on the winder whichever is preferred.

IEC has a set of experiment sheets that explores the various types of motors and generators that can be connected by using the Ucore and either the 300 or 600 turn coil.

Red LEDs close to the terminals indicate which terminal is positive. When AC, both LEDs blink on/off rapidly with the alternating voltage.

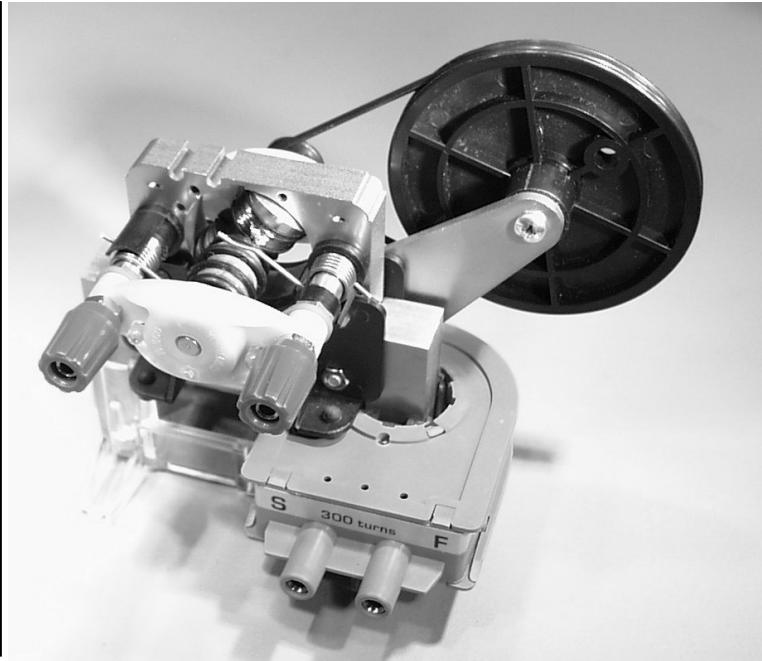

MOUNTING THE MOTOR/GENERATOR::

The motor/generator is designed to slide between the legs of the standard IEC 'Hodson' Induction Kit iron Ucore fitted with a single 300 or 600 turn coil. This Coil and Ucore creates the magnetic field that passes through the motor body. 6V.DC. applied to the 300 or 600 turn coil produces a DC magnetic field to easily run the motor or to generate a reasonable voltage and current. See image above showing the motor fitted to a Ucore.

U-CORE AND U-MAGNET::

When the motor is fitted to the Ucore, the U magnet becomes ineffective because the motor's iron circuit is effectively short circuited by the iron Ucore. The magnetic field from the magnet passes mainly through the Ucore rather than through the motor core and therefore the motor will not run.

THE LAMP LOAD::

The 'Lamp Load' is an MES globe, about 2.5V.300mA, which can be plugged into the output sockets to monitor the power generated. It is always removed from the terminals when the unit is to be run as a motor because the voltage applied to the motor could be say 6V and this would immediately burn out the lamp.

INTERESTING NOTE: Using either a field from the Ucore or from the U magnet, compare the winding effort on the handle firstly with the lamp load not fitted, then with the lamp load fitted. Then compare the winding effort with the output terminals short circuited together.

Notice the work that must be done on turning the rotor when current is produced.

The Brushes:

The term 'brush' refers to the contact to the commutator or slip-ring. It is usually a small block of carbon that rubs on the commutator to carry the current into the rotor. The IEC motor uses bronze wire as brushes and they should GENTLY but definitely rub on the rotating rings. The tension of the spring that presses the brushes is adjustable by partly loosening the screw that passes through the motor laminations from the handle side and slightly twisting the plastic collars that set the brush tensions. Then re-tighten the screws.

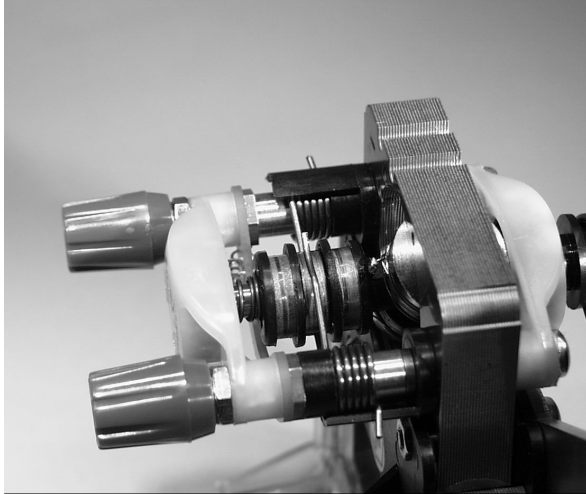

Brushes set for DC operation. Both brushes are contacting the centre ring (commutator).

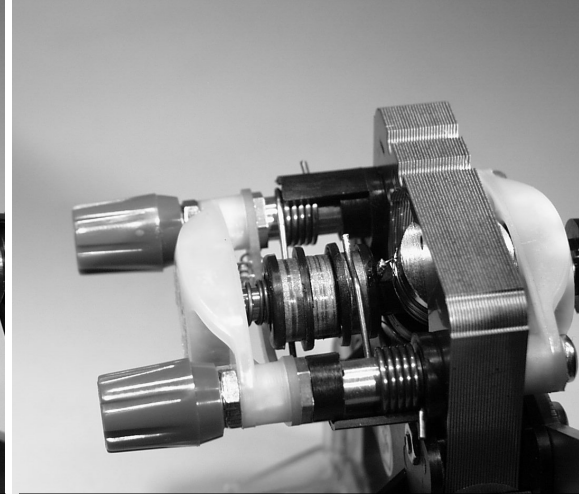

Brushes set for AC operation. Both brushes are contacting the outer rings (slip-rings).

To change the brush positions, turn off the power and use your fingertip to lift the tip of the brush and place it on the desired ring. Then slide the spring section across to align the brush correctly. **DO NOT ALLOW THE BRUSHES TO RUB THE INSULATION BETWEEN THE RINGS.**

Commutator and Slip-rings:

DC:: The 'Commutator' is the middle ring and it is divided into 2x segments. This motor has only 2x rotor windings, therefore as the rotor rotates, the direction of the current flowing in the rotor must be reversed at each half turn. The reversal of current in the rotor windings as the rotor rotates is necessary for a DC motor to run. In a real motor, there are many windings on the rotor, therefore there are many commutator segments causing reversal.

AC:: The Slip-rings are not segmented but are a continuous ring. They permit AC or DC current to flow into the rotor without the need to reverse it. There are several types of AC motor and some run by placing AC current on the rotor and AC current through the field windings too. Other types use DC on the rotor and AC on the field. In most cases, there is no need to reverse the current through the rotor.

The 'SERIES' type motor can run on either AC or DC and uses the commutator. See the various connections and much more information in IEC experiment sheets on motors.

77) D.C. GENERATOR

Permanent Magnet Field

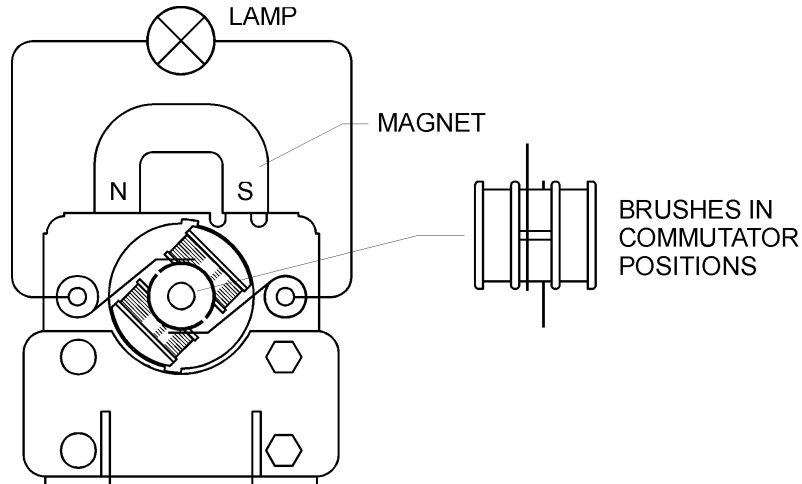

If the permanent magnet is used, the output voltage when running as a generator will be about 2 volts.

The red LEDs indicate which terminal is positive polarity. Winding backwards or reversing the direction of the magnet or the field coil will reverse the polarity of the output.

Adjustable Field

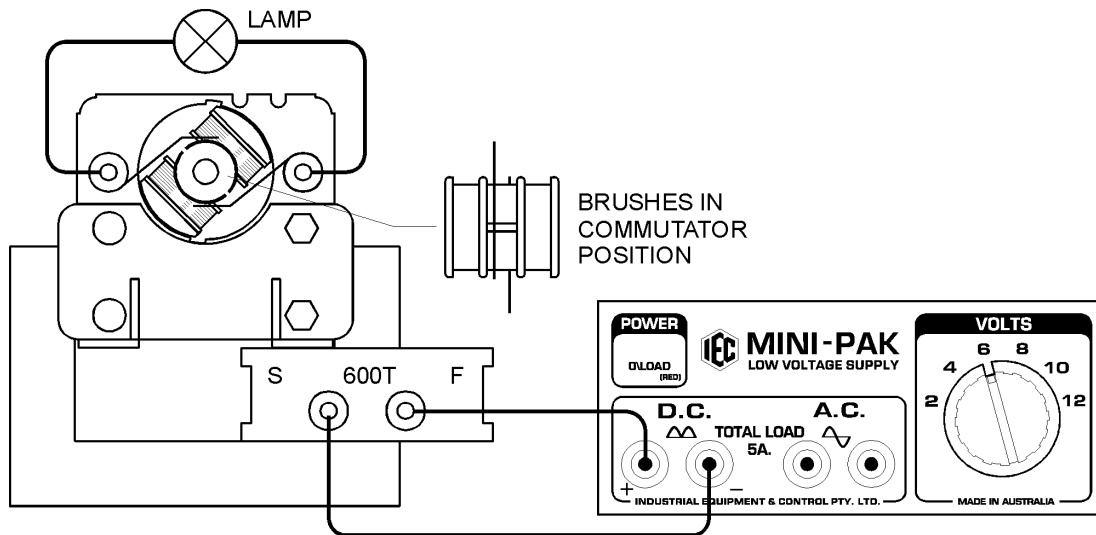

The hand wheel and belt can run the rotor at a speed that will generate about 6V.DC. if about 6V to 8V.DC. is applied to the 600 turn field coil. If the lamp socket load is plugged into the terminals, the lamp will glow as the handle is rotated briskly and about 4 to 6 V.DC. can be generated.

Notice the extra work required to turn the generator when running the lamp or if the terminals are short circuited. This is because the current generated is much larger.

78) A.C. GENERATOR

Permanent Magnet Field

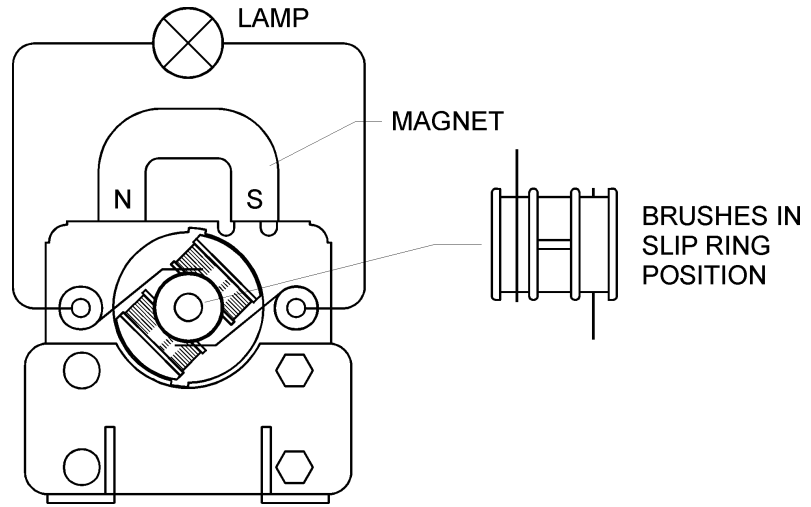

Adjustable Field

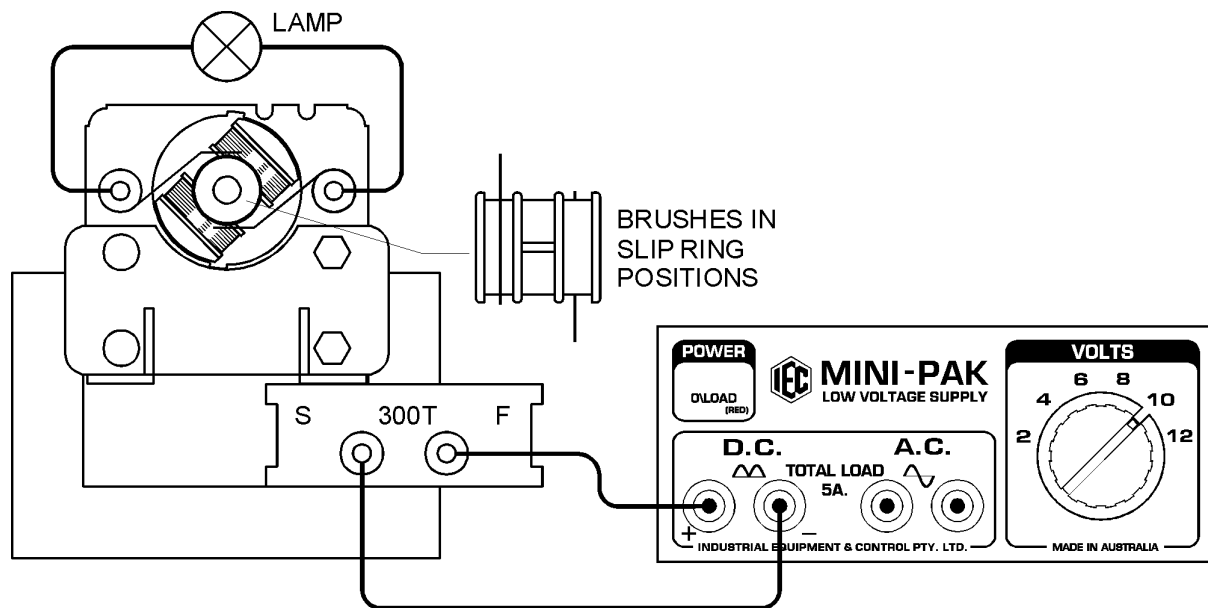

79) D.C. MOTOR

Permanent Magnet Field

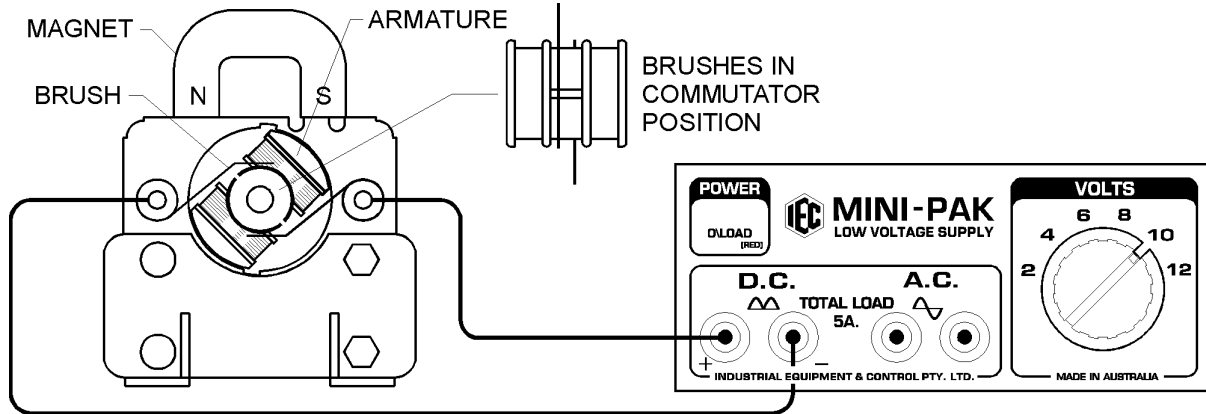

Alternatively, instead of using the Ucore, the U magnet or a few strong alnico bar magnets or a few super magnets can be placed on the edge of the motor's laminated iron core with north poles one side and south poles the other so that a DC magnetic field appears across the diameter of the motor. When using permanent magnets, the motor MUST NOT be mounted in the Ucore.

Shunt Connection

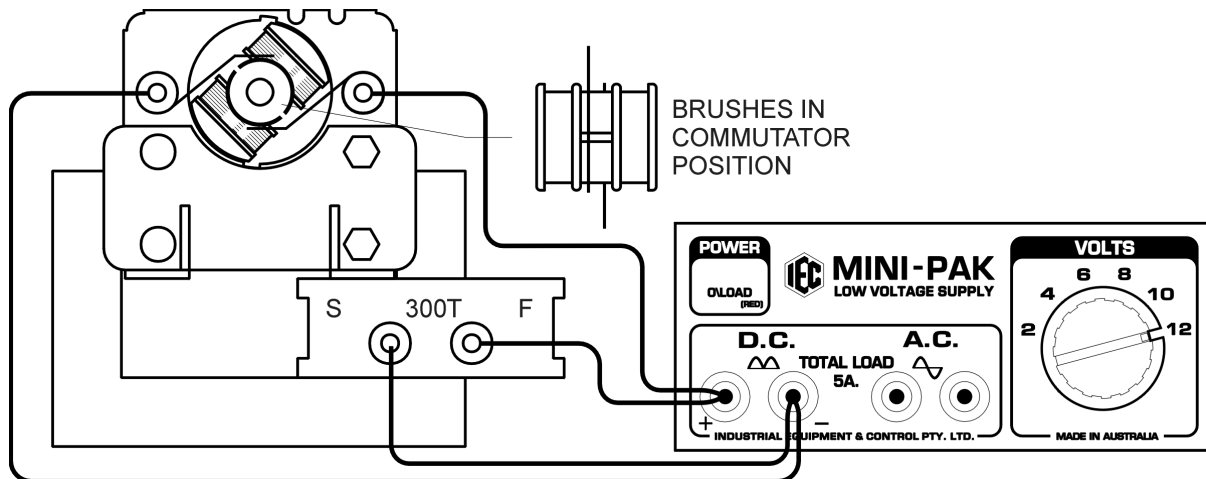

6V.DC. is connected to the 600 turn coil on the Ucore and also connected to the terminals on the motor. The iron rotor is magnetised by the current flowing through the rotor coils from the brushes and commutator which reverses the direction of the current as the rotor turns so that the rotor continues to rotate. This is because the magnetic field in the rotor is repelled from one side of the motor and attracted to the opposite side of the motor upon each reversal of current through the rotor.

D.C. MOTOR - Continued

Series Connection

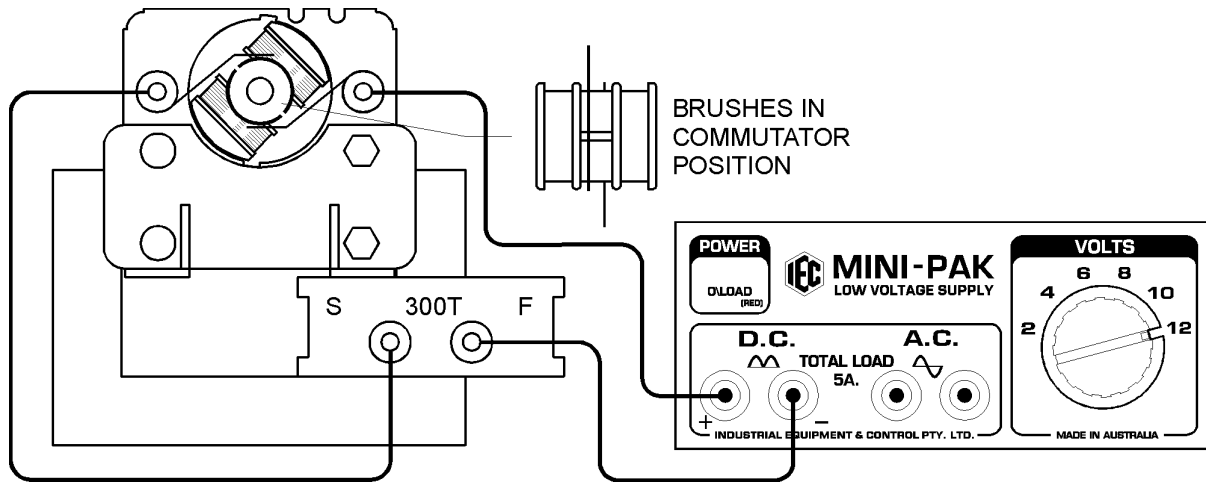

The motor armature can be connected in series with the field coil and this is called a 'series connection'. In this case, the same current is passed through the field and the armature and, because the ohms resistance is now higher, a higher voltage (say up to 12V.DC.) can be applied to the system.

80) A.C. MOTORS:

- Series Connection

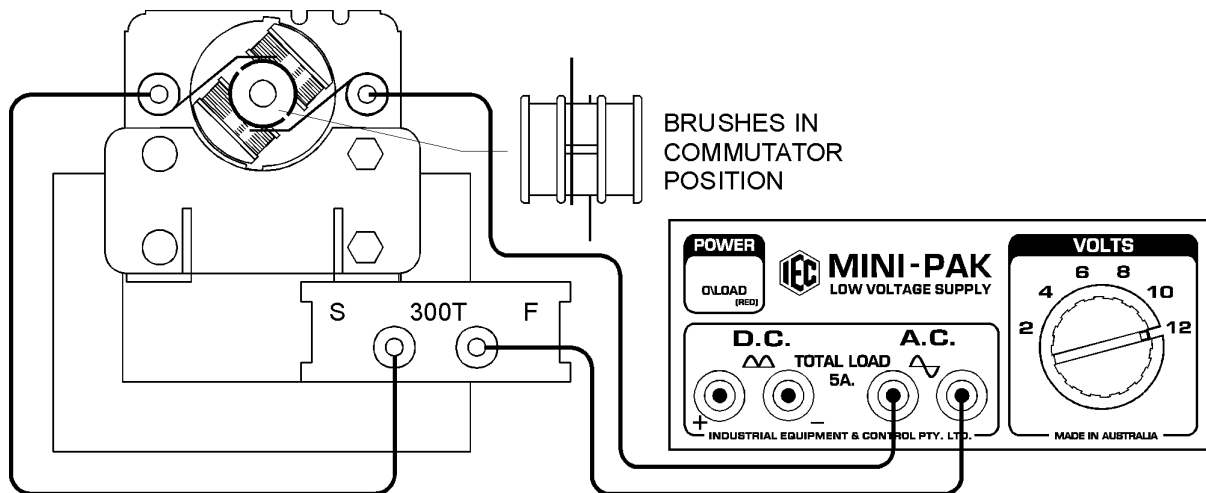

A.C. MOTORS – Continued

Synchronous Motor

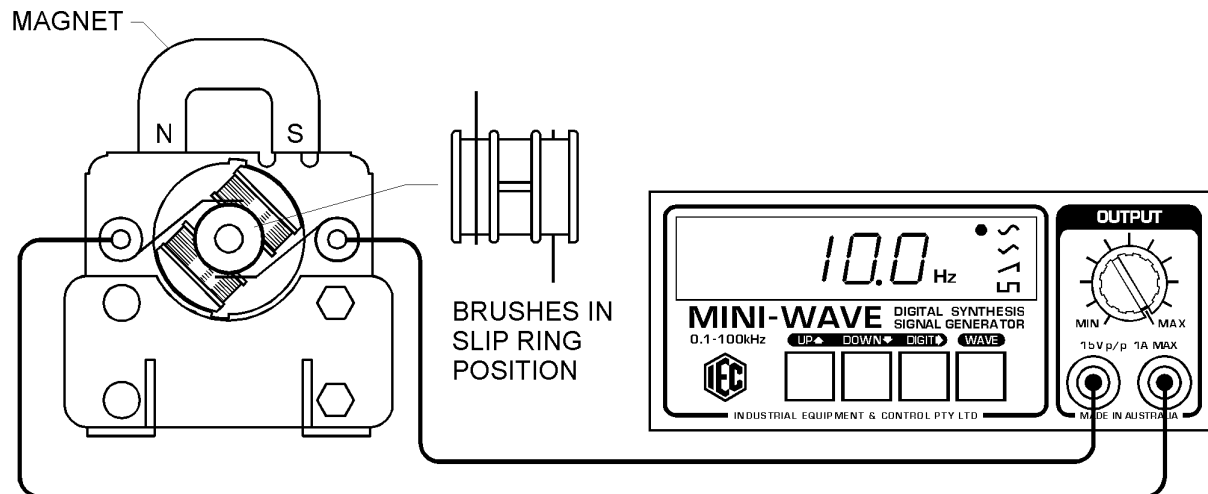

CARE AND MAINTENANCE:

The bronze wire brushes that rub on the commutator are adjustable for contact force. They are designed so that they are not easily bent or damaged by students, but if they should become bent out of shape they can be re-bent, but the following points are important:

- The points of contact where the brushes touch the commutator must be EXACTLY opposite one another to prevent one segment from short circuiting the supply.
- By partly loosening the screw that passes through the motor's iron core, the plastic collar can be rotated slightly to alter the force of the brush to the commutator. Both brushes should be gently but definitely pressing on the commutator.

Designed and manufactured in Australia



EXPERIMENT NOTES



EXPERIMENT NOTES