

# T8019L-SM DIMENSIONS

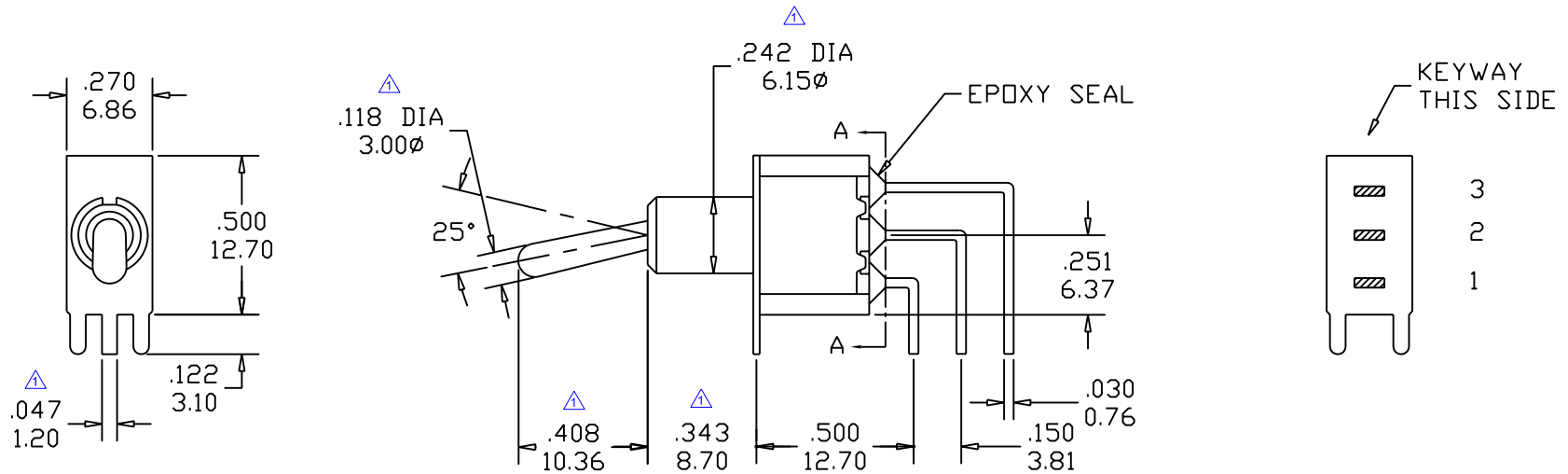

## Panel Mounting Dimension

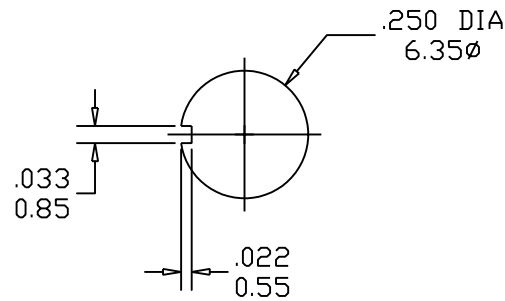

## P.C.B Mounting Dimension

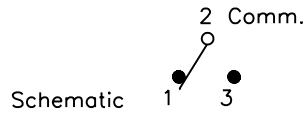
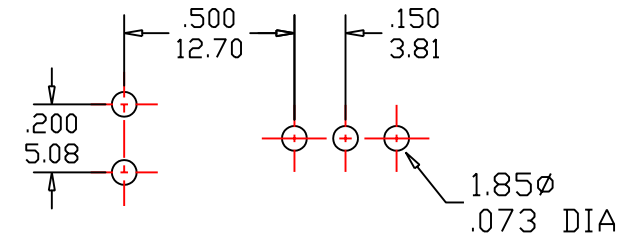

Model No.	Switching Position		
T8019L	ON	NONE	ON
T8019LA	ON	NONE	(ON)
T8020L	ON	OFF	ON
T8020LA	(ON)	OFF	(ON)
T8020LB	ON	OFF	(ON)
Term. Comm.	2-3	OPEN	2-1

2					General Tolerance		Part no. T8019L-SM	SH 興瀚企業股份有限公司 SALECOM. ELECTRONICS CO., LTD.	Approved	
	1	1	修正錯誤尺寸	07.07.19	Range	Tolerance			Dwg no. SWT8019L-010	Checked
0 ~ 1					±0.10	Part Name. T80-T / SPDT P.C. Mounted Toggle Switches	Scale 2:1			Drawer Jessica
0	NEW	05.11.11	1 ~ 4	±0.20	Unit m/m (inch)				Rev. 1	
Zone	Rev.	Description	Reviser	Date		4 ~ 16	±0.30			