

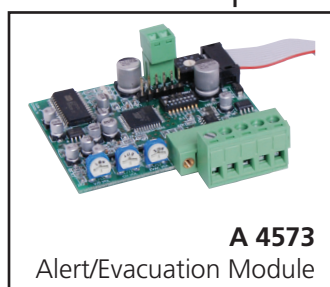

## Operating Manual

**A 4377A 125 WATT PUBLIC ADDRESS AMPLIFIER**  
**A 4387A 250 WATT PUBLIC ADDRESS AMPLIFIER**

### Optional Extras

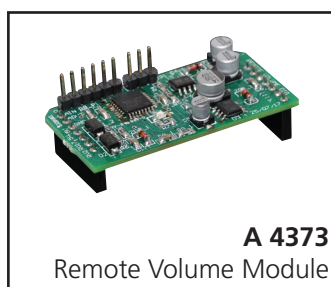

Redback® Proudly Made In Australia

Distributed by Altronic Distributors Pty. Ltd.  
 Phone: 1300 780 999 Fax: 1300 790 999 Internet: [www.altronics.com.au](http://www.altronics.com.au)

### IMPORTANT NOTE:

Please read these instructions carefully from front to back prior to installation.  
 They include important setup instructions.  
 Failure to follow these instructions may prevent the unit from working as designed.



**REDBACK** is a registered trademark of Altronic Distributors Pty Ltd

You may be surprised to learn that Altronics is still manufacturing hundreds of product lines right here in Australia. We have resisted the move offshore by offering our customers better quality products with innovations to save them time and money.

Our Balcatta production facility manufactures/assembles:

- Redback public address products
- One-shot speaker & grill combinations
- Zip-Rack 19 inch rack frame products

We strive to support local suppliers wherever possible in our supply chain, helping to support Australia's manufacturing industry.

## **Redback Audio Products**

100% developed, designed & assembled in Australia.

Since 1976 we have been manufacturing Redback amplifiers in Perth, Western Australia. With over 40 years experience in the commercial audio industry, we offer consultants, installers and end users reliable products of high build quality with local product support. We believe there is significant added value for customers when purchasing an Australian made Redback amplifier or PA product.

## **Local support & feedback.**

Our best product features come as a direct result of feedback from our customers, and when you call us, you speak to a real person - no recorded messages, call centres or automated push button options.

It's not only the assembly team at Altronics who are employed as a direct result of your purchase, but hundreds more at local companies used in the supply chain.

## **Industry leading 10 year warranty.**

There's a reason we have the industry leading DECADE warranty. It's because of a long tried and tested history of bullet-proof reliability. We've heard PA contractors tell us they still see the original Redford amplifier still in service in schools.

We offer this comprehensive parts & labour warranty on almost every Australian Made Redback public address product. This offers both installers and end users peace of mind that they will receive prompt local servicing in the rare event of any problems.

## OVERVIEW

The Redback A 4377A 125 Watt and A 4387A 250 Watt 4 channel mixer amplifiers are specifically designed for applications requiring up to three microphone inputs, without compromising output power and overall performance. The amplifiers feature three inputs which can be configured for either microphone or line level operation.

The A 4377A conservatively delivers 125W RMS power, while the A 4387A delivers 250W RMS. Frequency response extends from 50Hz to 15kHz  $\pm 3$ dB at a total harmonic distortion (THD) of less than 0.5% @ 1kHz.

Vox muting is provided on inputs one and two, which, when activated, automatically mutes the other inputs. Bass and treble controls and phantom powering capability enable unparalleled flexibility for a wide scope of applications such as factories, workshops, mine sites, sports clubs and office buildings.

The amplifiers operate from 240V AC mains or 24V DC permitting battery backup operation during mains power failure. The output comes standard suitable for a 100V line load, but this can be configured internally to 70V line or low impedance (4 - 16 $\Omega$ ) loads. (Check the Website for details).

Thermal overload, overcurrent and overload protection circuitry and fuses on both AC and DC provide excellent fault condition protection and robust performance. The amplifier also utilises a half power mode which enables the amplifier to continue to run at a reduced output level if it is being over driven.

Tape output sockets are provided for recording purposes or feeding into additional power amplifiers.

Remote volume available when A 4373 Digital volume control module fitted internally and external A 2280B wall plate or 1K $\Omega$  potentiometer connected.

Alert and Evacuation tones (conforming to AS1607.4) along with chime tones and voice over message option available when optional A 4573 fitted.

## FEATURES

- 3 Balanced microphone inputs / 3 Aux inputs / 1 Music input
- Robust design incorporating latest Mosfet technology
- Very Low noise and distortion
- 100V standard with optional 70V and 4-16 $\Omega$  outputs
- 240V AC or 24V DC operation
- VOX muting on inputs 1 and 2 (Switch selectable internally)
- Adjustable VOX level sensitivities
- Bass and Treble controls
- Tape Output
- Phantom power on microphone inputs (DIP switch selectable internally)
- Multi stage thermally cued fan cooling
- Output Peak Limited
- Thermal Overload protected
- Signal Presence Indicator
- Half power mode when overdriven
- Fault Indicators
- 24V DC Power Status Indicator
- Optional Alert/Evac module with voice over message for emergency tones (A 4573)
- Optional remote volume (With A 4373 Digital volume control module fitted and external A 2280B wall plate)
- Rack Mountable (suits 19 inch racks) with optional A 4376 rack ears

# Redback® 125/250Watt Mixer Amplifiers

Figure 1 shows the layout of the front panel.

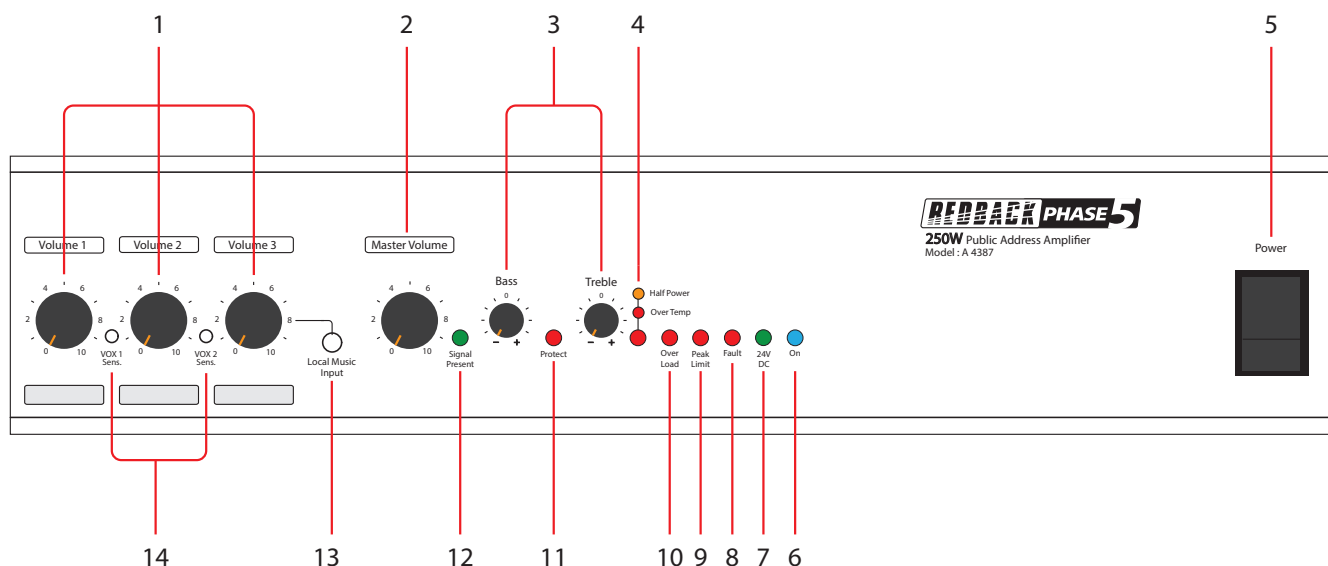

Fig 1

- 1 Inputs 1-4 volume controls**  
Use these controls to adjust the output volume of inputs 1-4 (volume 3 is used to adjust the volume of input 4 the music input).
- 2 Master volume Control**  
Use this control to adjust the master volume.
- 3 Bass and Treble Controls**  
Use these controls to adjust the bass and treble.
- 4 OverTemp/ Half Power Indicator**  
When this LED is red it indicates when the amplifier is overheating. The output will be disconnected until the amplifier is once again cool enough to operate. If this LED is orange the amplifier has gone into half power mode. This mode lets the amplifier continue to run at a lower output rather than shutdown completely. This mode might be initiated from the amplifier being overdriven or overloaded.
- 5 Power Switch**  
Use this to turn the unit on.
- 6 On Indicator**  
This led indicates the unit has power.
- 7 24V DC Indicator**  
This LED indicates when the amplifier is being powered from the 24V input.
- 8 Fault Indicator**  
This led indicates when the amplifier has a fault.
- 9 Peak Limit Indicator**  
This LED indicates when the input signal is clipping.
- 10 OverLoad Indicator**  
This LED indicates when the output is drawing too much current from the amplifier. The output will be disconnected until the current draw is reduced.
- 11 Protect Indicator**  
This LED indicates when the amplifier module has an internal circuitry fault.
- 12 Signal Presence Indicator**  
This LED indicates when an input signal is present.
- 13 Music Input**  
Use this input to connect a portable music player. This input over-rides the rear input 3 and is adjusted via the volume 3 pot.
- 14 Vox level controls**  
Use these controls to adjust the vox sensitivities of inputs 1-2.

Figure 2 shows the layout of the rear panel.

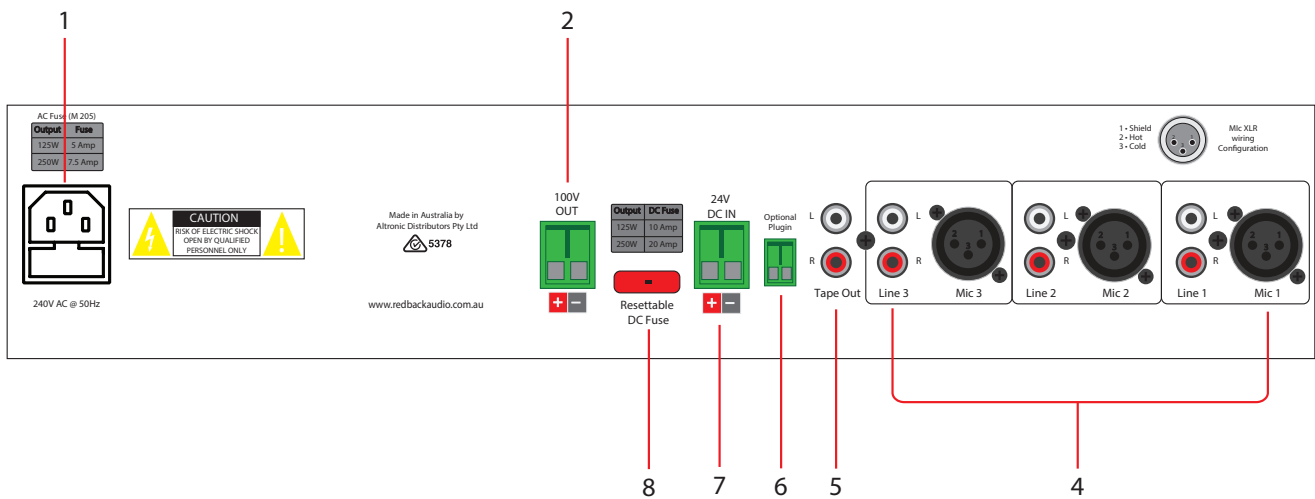

Fig 2

**1 240V AC power socket (Australian standard)**

Connects to 240V AC mains power with the included IEC lead. The internal fuse is an M205 5Amp for the A 4377A 125 Watt amplifier and an M205 7.5Amp for the A 4387A 250 Watt amplifier.

**2 Output Connections**

Speakers fitted with a 100V line transformer may be connected to these terminals. Always ensure that the total load of the speakers does not exceed the rated output of the amplifier i.e. 80Ω minimum at 100V for 125W and 40Ω minimum at 100V for 250 Watts. Otherwise either the DC or mains fuse could blow or the fault led activate and the amp will shut down. Always be careful to avoid short circuits and connection to the wrong terminals.

**3 Optional Alert/Evacuation Tone Generator with Voice Over Message**

When fitted this card provides standard Alert and Evacuation tones which conform to AS1607.4. A voice over message can be recorded to the card and various chime tones are included.

**4 Inputs 1-3**

These inputs can be either a balanced XLR input with sensitivities of 500mV or dual RCA line inputs with a 1V input sensitivity. The line input dual RCA connectors are internally mixed to produce a mono input signal.

**5 Tape Out**

Dual RCA's provided for recording purposes. This is a line level output.

**6 Optional Plugin**

This connection is to be used when the optional A 4373 Digital Volume Board is fitted inside the amplifier. This provides remote volume when used in conjunction with a 1K potentiometer wired to these terminals.

**7 24VDC IN**

Battery Backup: Provision has been provided to run the amplifier from a suitably rated 24V battery system in the event of a mains failure. Using appropriately rated cable, connect the battery to the "24V DC In" terminals. Observe correct polarity when connecting. (see Fig 5 for more details)

**8 DC Resettable fuses**

This fuse protect the internal power supply. If the fuse is tripped it is easily reset by pressing the small button on the fuse.

# Redback® 125/250Watt Mixer Amplifiers

## SPEAKER CONNECTIONS

Speakers fitted with 100V line transformers may be connected to the output terminals on the rear of the amplifier. Always ensure the total load of the fitted speakers does not exceed the rated output of the amplifier (ie 125 watts for the A 4377A and 250 watts for the A 4387A amplifier) otherwise damage may result. When fitting speakers with line transformers the impedance of the load cannot be measured using a standard multimeter. An impedance meter is required. Fig 3 lists the impedance at certain loads of speakers fitted with 70V and 100V line transformers. So for a total load of 125 watts using 100V line transformer fitted speakers, the impedance of the speaker load should be 80Ω.

**i About 70V & 100V Line Speaker Systems**

**Wiring speakers in parallel for 70/100V line:** Where several speakers are to be used at one time, on one circuit, it becomes necessary to use speakers fitted with line-matching transformers. This is to overcome the effects of connecting speakers in parallel and cable losses. The amplifier generally has an output voltage of 100 volts (70 volts is typically used in North America, however operation is similar). In this configuration the total wattage load on the amplifier is derived from adding all the line transformer primary tap ratings together. For example, 70 one watt speakers will have a total speaker load of 70 watts. Or alternatively, it is conceivable to connect 100 one watt speakers to a 100 watt, 100 volt line amplifier.

**Measuring 70/100V Line Speaker Impedance:** To measure amplifier system load, you must use an impedance meter in order to measure the ac resistance of the connected speaker network. Impedance cannot be measured with a standard multimeter, as this measures the dc resistance. Use the Altronics Q 2001 or similar impedance meter.

Load	70V	100V
0.5W	9.4kΩ	20kΩ
0.66W	7.12kΩ	15kΩ
1W	4.7kΩ	10kΩ
1.25W	3.76kΩ	8kΩ
2W	2.35kΩ	5kΩ
2.5W	1.88kΩ	4kΩ
3W	1.56kΩ	3.3kΩ
5W	940Ω	2kΩ
7.5W	626Ω	1.3kΩ
10W	470Ω	1kΩ
15W	313Ω	666Ω
20W	235Ω	500Ω
30W	156Ω	333Ω
40W	117Ω	250Ω
60W	78Ω	166Ω
100W	47Ω	100Ω
125W	37Ω	80Ω
250W	19Ω	40Ω
500W	9.4Ω	20Ω

Fig 3

## AUDIO CONNECTIONS

The amplifier has three balanced XLR audio inputs, three dual RCA line inputs which are internally mixed to create mono signals and a front mounted Music Input for portable devices. This input when connected, over-rides the rear channel 3 audio sources and is adjusted via the volume 3 level control. A VOX function is also included which when enabled will allow input 1 to mute inputs 2 and 3, or input 2 to mute input 3. The VOX circuitry is selected by internal switches as shown in figure 5. The VOX1 switch when set to ON will allow input 1 to mute inputs 2 & 3. The VOX2 switch when set to ON will allow input 2 to mute input 3. The VOX sensitivity is adjusted by the trimpots located on the front of the amplifier.

### Mic XLR wiring Configuration



- 1 • Earth/Shield
- 2 • Signal Hot
- 3 • Signal Cold

Fig 4 shows a typical install where the A 4377A has a balanced microphone connected to input 1 and a Line level source connected to input 2. If the VOX1 switch is set to "ON", the microphone will VOX mute the CD player connected to input 2.

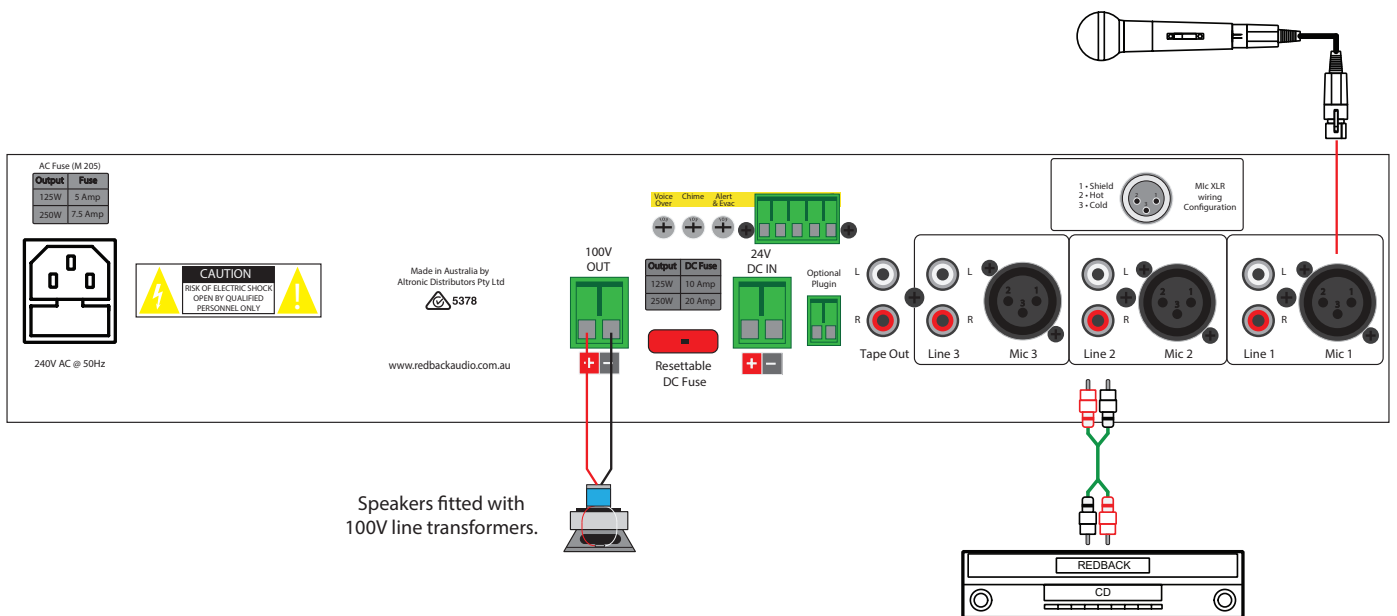

Fig 4

## PHANTOM POWER

All three microphone inputs have DIP switch selectable phantom power. When enabled 15V DC will be connected to the Hot and Cold pins of the corresponding XLR. To access the DIP switches, first disconnect power from the unit and then remove the lid. The location of the DIP switches is shown in figure 5.

The Phantom power DIP switch settings are:

- DIP 1 enables the phantom power to the XLR connector on input 1.
- DIP 2 enables the phantom power to the XLR connector on input 2.
- DIP 3 enables the phantom power to the XLR connector on input 3.
- DIP 4 is not used.

## VOX MUTING

Vox muting is provided on inputs one and two, which, when activated, automatically mutes the other inputs. The VOX1 switch when set to ON will allow input 1 to mute inputs 2 & 3. The VOX2 switch when set to ON will allow input 2 to mute input 3.

The VOX sensitivity is adjusted by the trimpots located on the front of the amplifier (see figure 1).

## REMOTE VOLUME (Optional)

It is possible to control the master volume with the addition of the A 4373 Digital Remote volume board and a 1k $\Omega$  potentiometer (or Altronics A 2280B wall plate) fitted across the terminals labelled "Optional Plugin" on the rear of the amplifier. The plugin board is fitted inside the amplifier in the location shown in figure 5.

*NOTE: Take special care with the orientation of the board and remove power from the amplifier before fitting.*

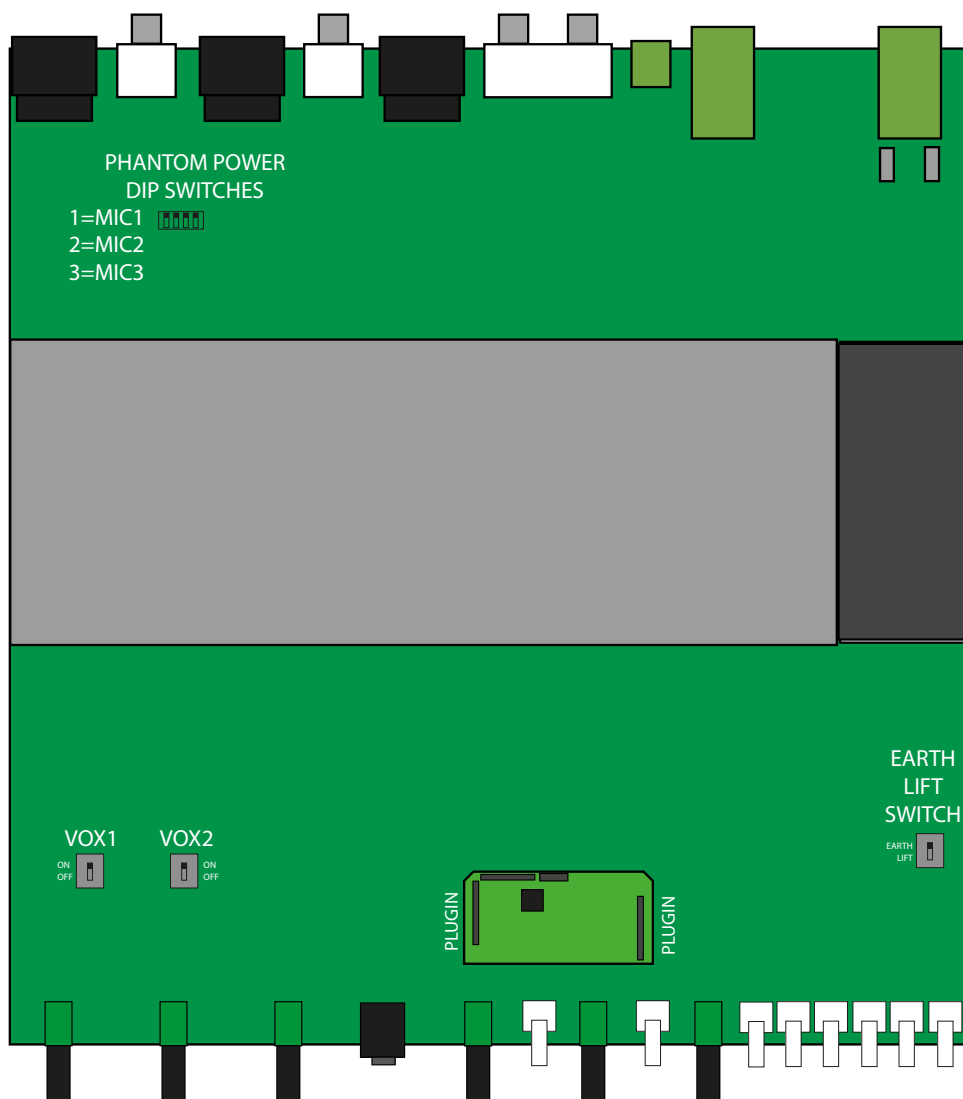

Fig 5

# Redback® 125/250Watt Mixer Amplifiers

## POWER SUPPLY

The amplifier operates on 230V AC or primarily for battery backup operation a 24V DC supply. Ensure power is switched OFF at the front panel before connecting either mains power to the IEC socket or 24V DC to the screw terminal input. As high currents may be drawn when operating from a 24V DC supply confirm the capacity of the DC power supply used.

## TROUBLESHOOTING

If the REDBACK Phase 4 amplifier fails to deliver the rated performance, check the following:

### No Power, No Lights

Make sure amplifier power switch is on. Make sure mains power switch is on at the wall. Check the mains and DC fuse. Replace with only the correct type and rating. Over rated fuses will invalidate warranty.

### Distorted Output

Check that the speaker type is correct for the output that you are using (ie. 100V line). Check for any short circuits on the speaker line.

### Very Low Output Volume

Make sure that the input is the correct level (check for shorted connectors). Check for any short circuits on the speaker line.

Check if signal LED on the front panel is lit to indicate there is signal. If it is not lit there is no signal present.

### Continually Blows Fuses

Make sure that the speaker line is not shorted. Check speaker types, ratings and if on correct output.

### Amplifier Keeps on Cutting In & Out

Make sure that there is adequate ventilation around the amplifier. Check the vent slots on the front, top and sides are not covered or blocked and the fan on the rear is functioning correctly. Check also speaker types, ratings and for any short circuits on the speaker line.

## SPECIFICATIONS

### POWER OUTPUTS

Power: .....A 4377A -125 watts RMS

..... A 4387A - 250 watts RMS

Distortion:.....< 0.5%, @ 1kHz

Output line: ..... 100V

### FREQUENCY RESPONSE

Mic inputs :.....50Hz - 12kHz, -3dB

Line inputs: .....50Hz - 15kHz, -3dB

### MIC SENSITIVITY

Mic inputs: ..... 3mV

Line inputs:.....1V

Music input: .....500mV

### SIGNAL TO NOISE RATIO

Mic inputs: ..... > 75dB below rated output

**LINE OUTPUT** ..... 600Ω balanced, 0dB , 3 Pin XLR

### OUTPUT CONNECTORS

Speakers: .....Screw terminals

### INPUT CONNECTORS

Inputs: .....3 pin XLR balanced or 2 x RCA

24V DC power: .....Screw terminals

240V AC power: ..... IEC power connector

**MUTING:**..... PTT via microphone switch contacts

..... VOX muting (inputs 1-2)

### CONTROLS

Mic/Line/Music inputs: ..... Volume

Power: .....On/off switch

Indicators:.....Power, signal present, output peak limiting, overtemp ,Overload Protect, Half Power, 24V DC

**POWER SUPPLY:** .....240V AC or 24V DC

**FUSE PROTECTION:** .....125W - 5A AC ,10A DC

.....250W - 7.5A AC ,20A DC

**DIMENSIONS** .....~483W x 300D x 88H

**WEIGHT:** ..... A 4377A ≈ 11kg

..... A 4387A ≈ 15.5kg

### CURRENT DRAW:

A 4377A ..... Min ≈ 300 mA

..... Max ≈ 9.6A

A 4387A ..... Min ≈ 350 mA

..... Max ≈ 20A

\* Specifications subject to change without notice

All Australian made Redback products are covered by a 10 year warranty.

Should a product become faulty please contact us to obtain a return authorisation number. Please ensure you have all the relevant documentation on hand. We do not accept unauthorised returns. Proof of purchase is required so please retain your invoice.