



**REDBACK**<sup>®</sup>

# C 2052 Wurli-Gig Horn Speaker Mounting Accessory

- Designed for use with Redback C 2053 and C 2056.
- UV stabilised for both indoor and outdoor use.
- Reduces installation time by up to 50%.

## STEP ONE:

Fix Wurli-Gig bracket to mounting surface using appropriate fixings. For brick and concrete, we recommend minimum 50mm green wallplugs and 8G self tappers.

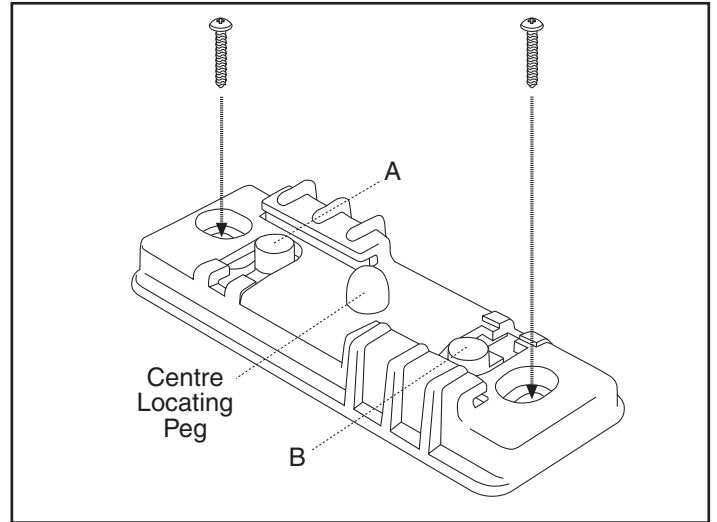

## STEP TWO:

For best results, using both hands, grip the metal U bracket at points marked 'X'.

Place horn on centre locating peg, ensure the metal U bracket engages the spring loaded tabs marked 'A' and 'B'.

Push the horn downward and twist until you hear a click. The spring loaded tabs will now be locked into the holes.

Ensure both tabs 'A' and 'B' are engaged firmly into the 2 holes in the metal U bracket.

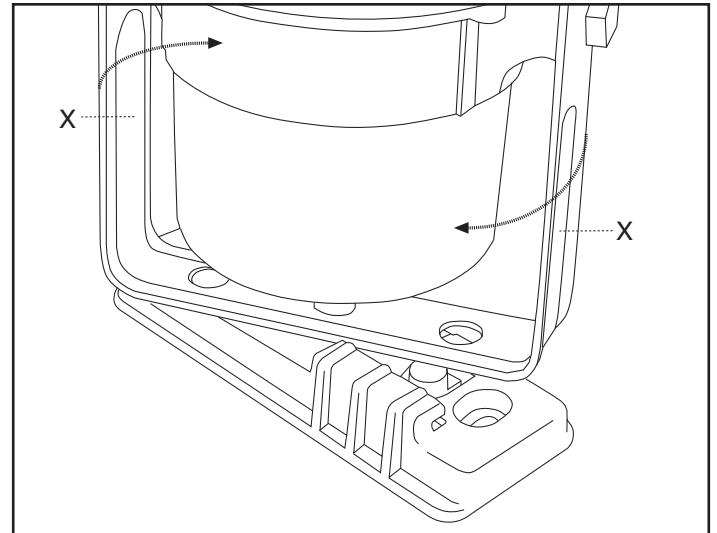

## HORN REMOVAL:

The horn can be removed by disengaging the springloaded tabs 'A' and 'B'. To do this, place a screwdriver into the keyhole shown. Lever the first tab out of the metal bracket and twist the horn to prevent the tab from re-engaging the hole. Then lever the second tab out and twist the horn. It will then come away from the Wurli-Gig.

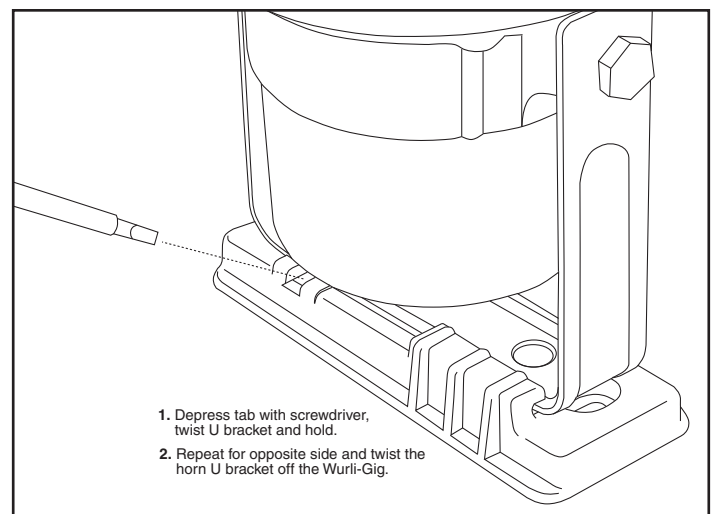

**Note:** It is the installers responsibility to determine if the Wurli-Gig bracket is suitable for their installation or application

**The Wurli-Gig is proudly made in Australia by Altronic Distributors Pty. Ltd.**

• Sydney • Melbourne • Brisbane • Perth • Adelaide

Phone: 1300 780 999 Fax: 1300 790 999 Internet: [www.altronic.com.au](http://www.altronic.com.au)

Registered Design - Patent Pending.