

Step 6: Screw on lid using M3 (A) type screws.

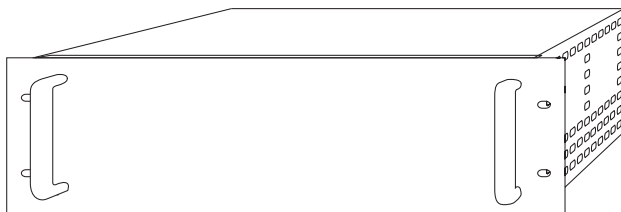

H 5038/39 CUSTOMISABLE RACK CASE

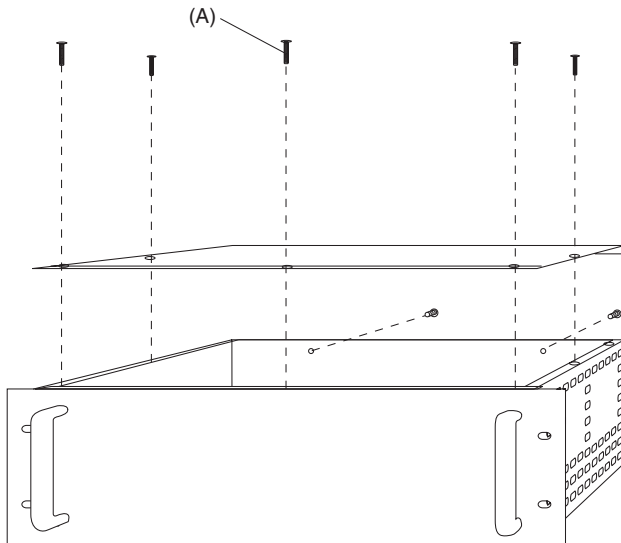

ASSEMBLY INSTRUCTIONS

Contents:

- 1 x Front Panel
- 1 x Internal Panel
- 1 x Top Panel
- 1 x Bottom Panel
- 1 x LH Side Panel
- 1 x RH Side Panel
- 2 x Handles
- 4 x Mounting Channels
- 30 x M3 Countersunk Screws (A)
- 18 x M4 Screws (B)

Step 1: Screw handles to front panel using M4 (B) type screws.

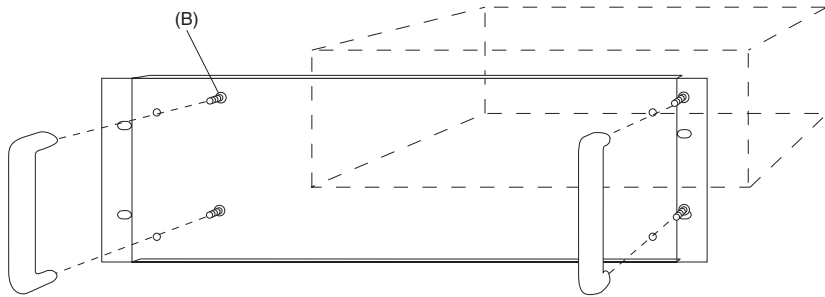

Step 2: Screw side & rear panels together using M3 (A) type screws.

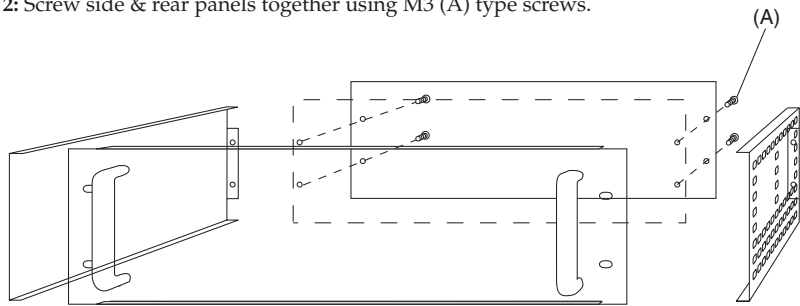

Step 3: Screw side & rear panels to the front panel using M3 (A) type screws.

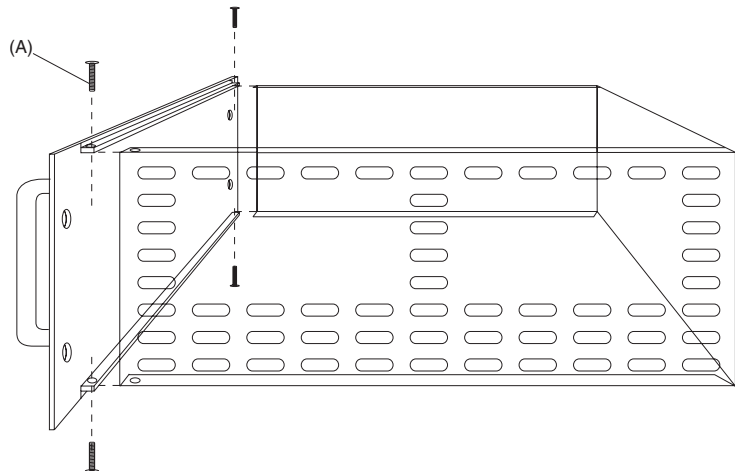

Step 4: Screw bottom panel onto the case assembly using M3 (A) type screws.

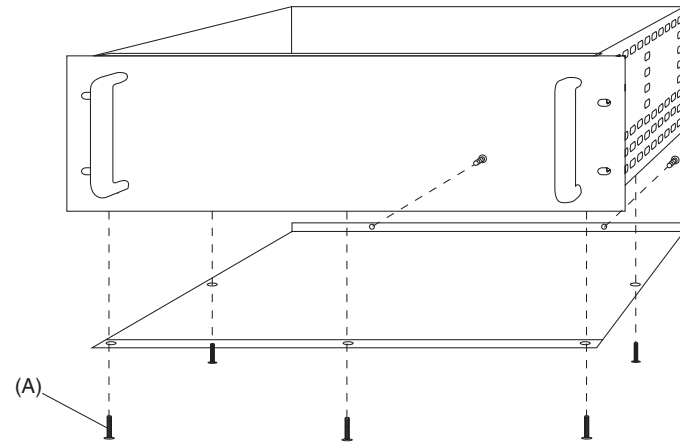

Step 5: Screw in internal mounting channels as required, using M4 (B) type screws. The internal frame can be used as a front or rear panel sub frame. Alternatively it can be mounted horizontally at a choice of 3 heights as a base plate sub frame.

